

# تصميم معماري III



م.علي سعد عبد الوهاب

المحاضرة رقم 6 - الأسبوع السادس

كيفية خلق افكار تصميمية

مشروع تصميم فندق 5 نجوم في محافظة المثنى

جامعة المثنى

كلية الهندسة

قسم هندسة العمارة



WRAPPING

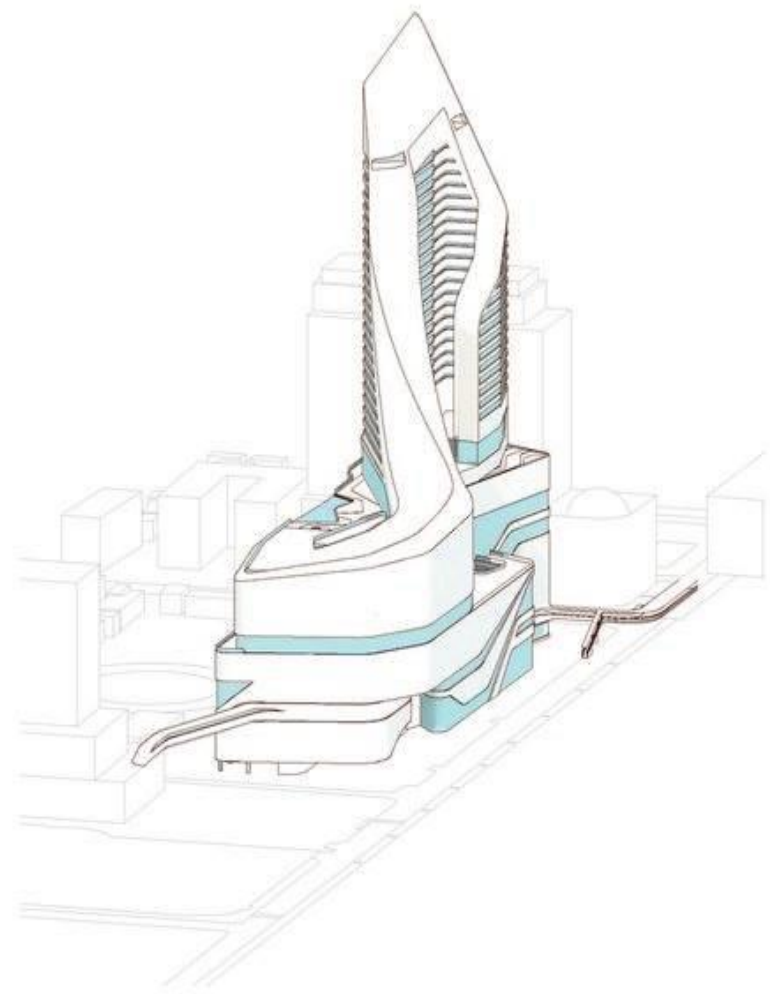
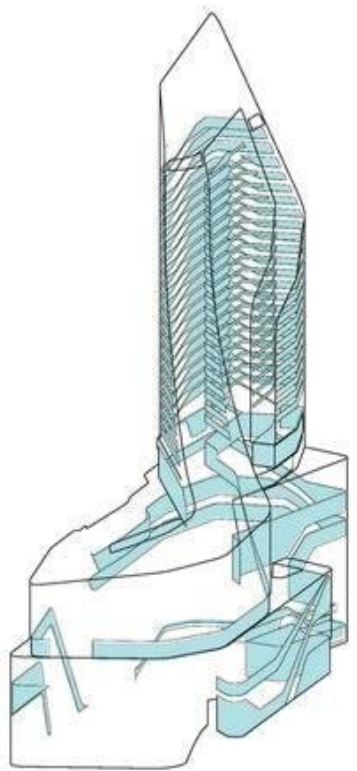

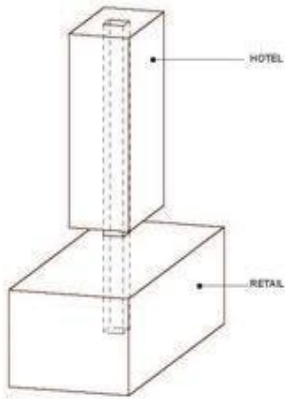

01 TOWER + PODIUM

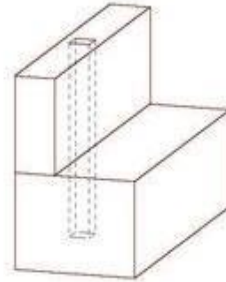

02 DOUBLE LOADED

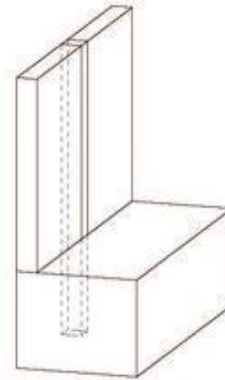

03 SINGLE LOADED

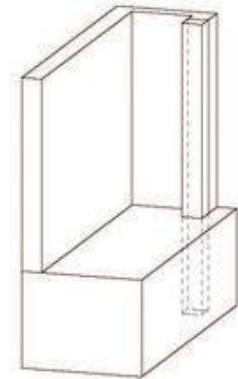

04 SINGLE LOADED

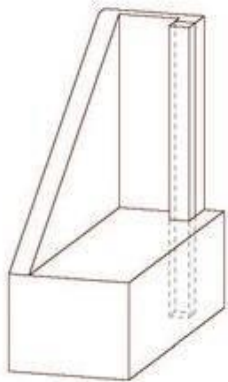

05 TERRACED TOWER

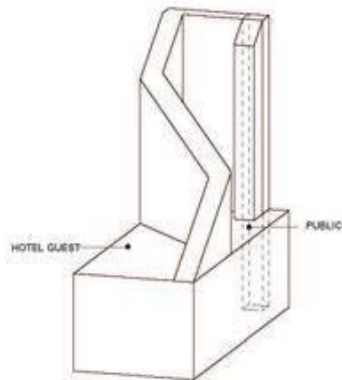

06 TOWER AS SPACE DIVIDER

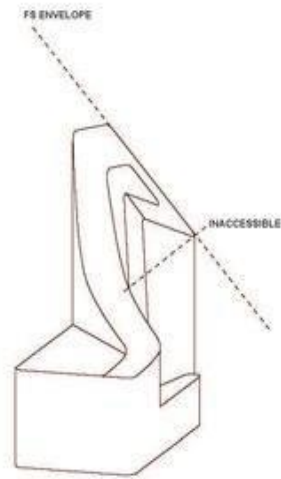

07 ENVELOPE ADJUSTMENT



08 FINAL ENVELOPE





Guard Rail / Bollard



Clock / Reclining Bench



Info Kiosk / Shade



Bench Cluster



Planter / Bench



Picnic Table



Wave Bench



Split Bench



Wiggle Bench



Curve Bench



Lift Bench



Planter Bench



Bench Bench



+ Bench / Planter



+ Reclined Bench

## Multi-use Follie

Using the same language, we create multiple places to stay, play and entertain along the south dock path.



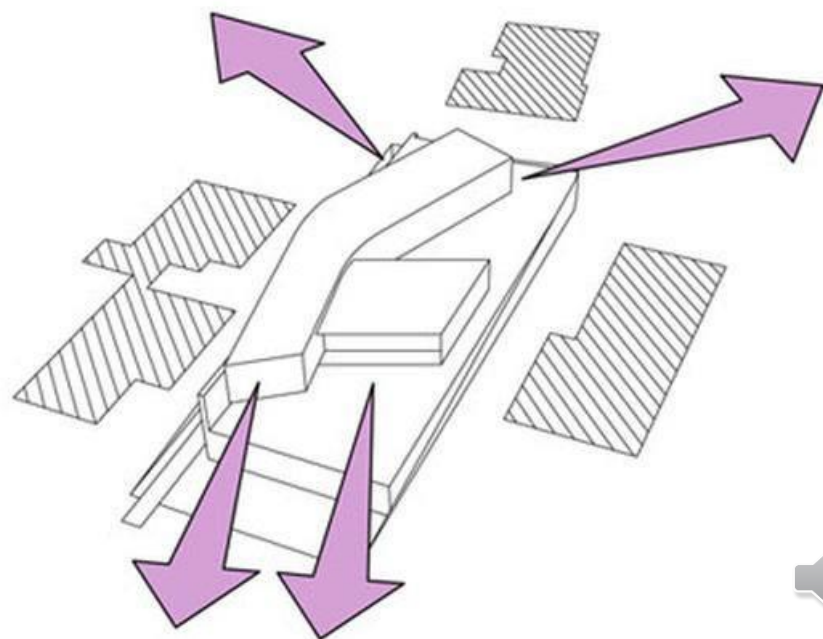
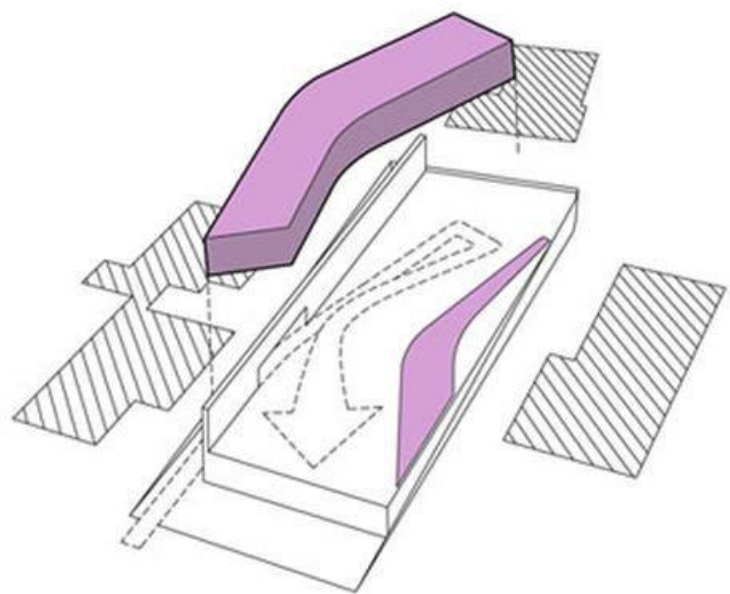
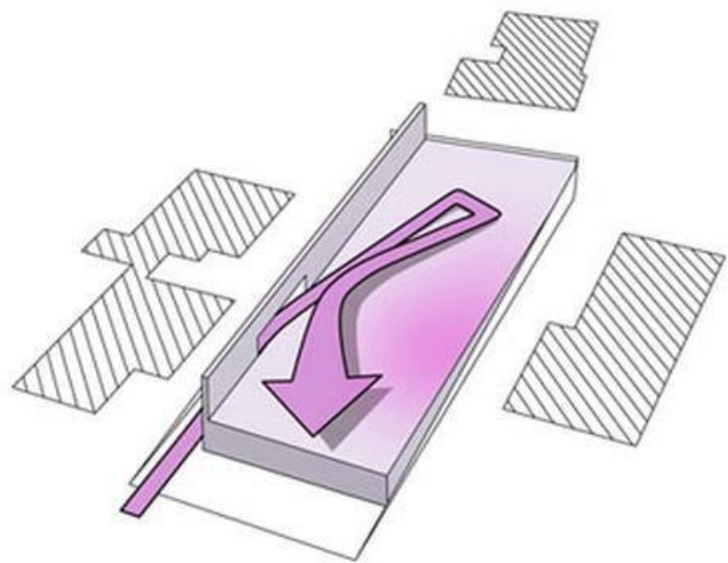
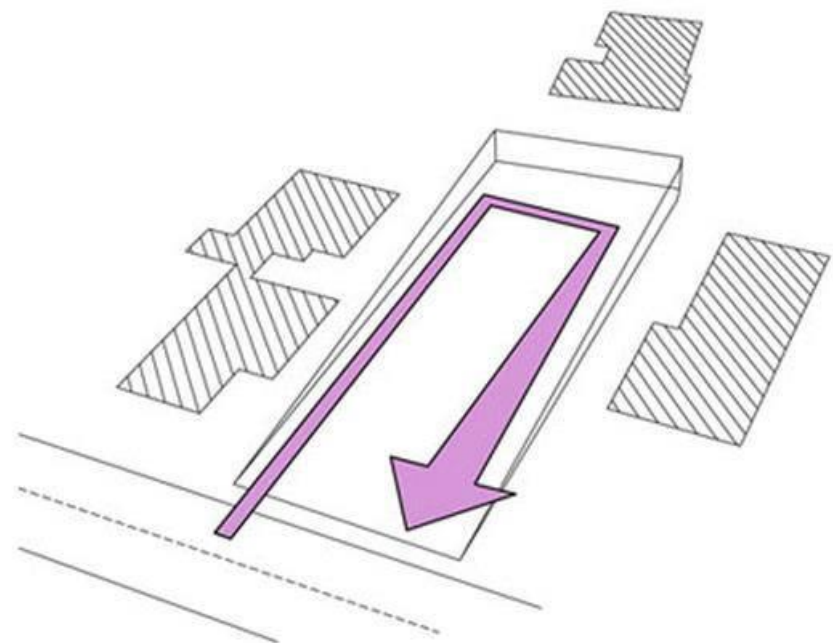

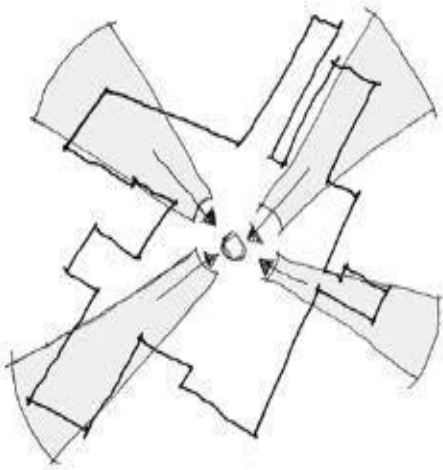

Opening the site and increasing access

Series of public spaces, leading to a new central square, defined by vertical element

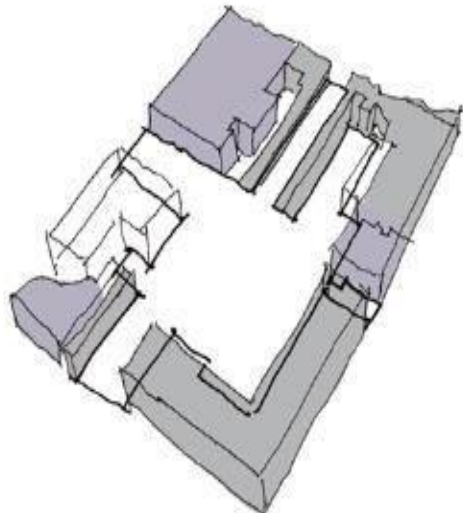

Consideration of older site and urban context, uses of existing buildings

External spaces and building form defined by planes

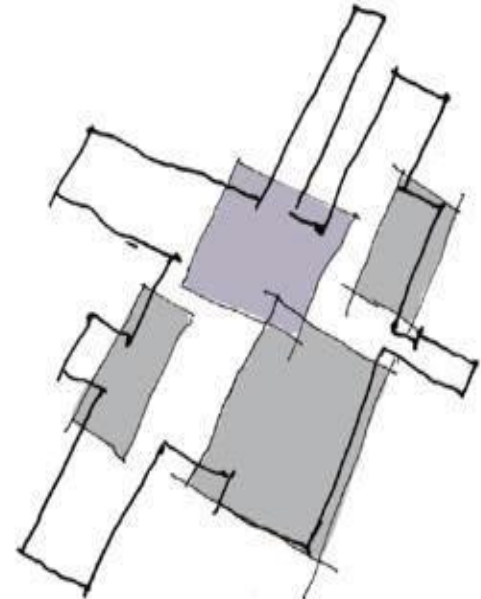

The older urban context to determine spatial arrangement of scheme

Landscaping of Public Realm, use of the "streets" to connect the spaces

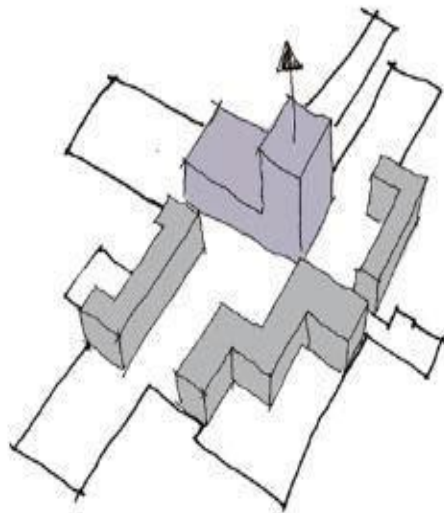

Creation of urban blocks, defined by external spaces, and location of vertical element

Landscaping of Private Realm, reflection of internal layout on formally defined spaces

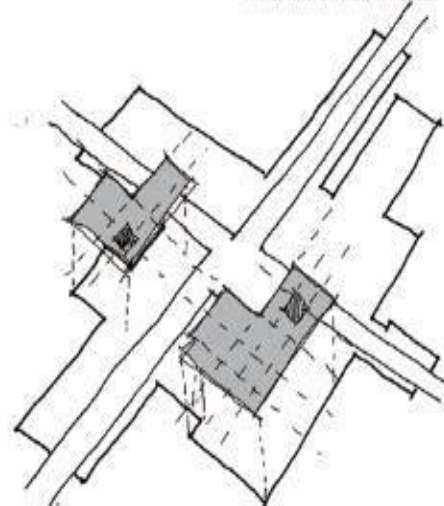
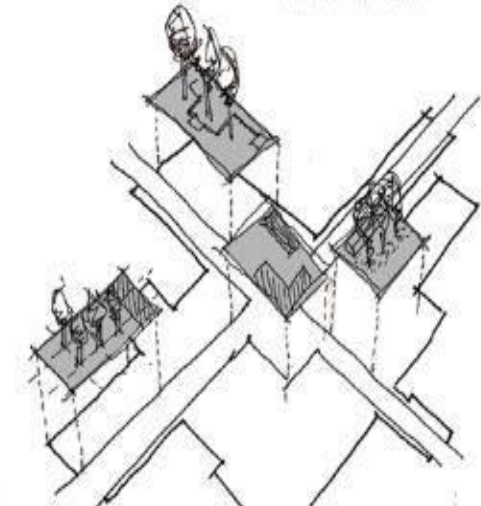
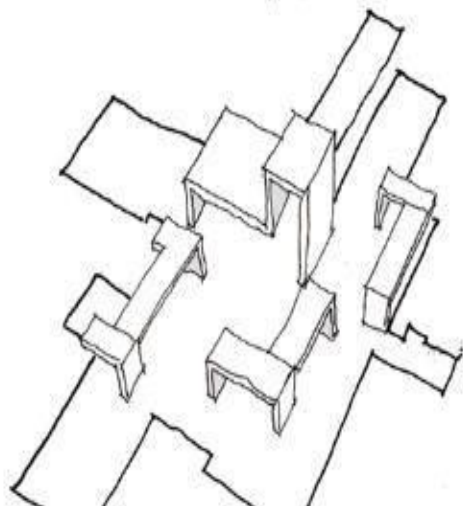
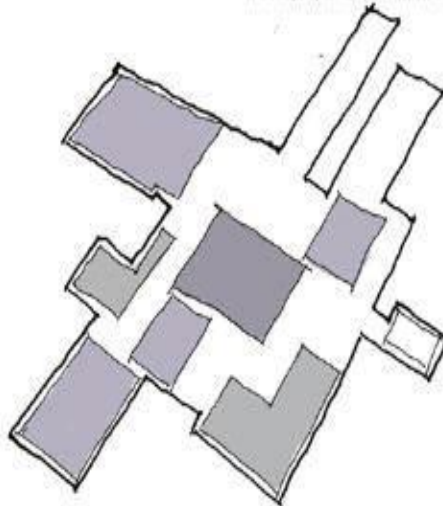

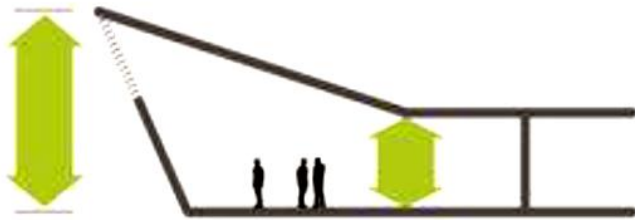

DOUBLE HEIGHT SPACE IN GALLERY

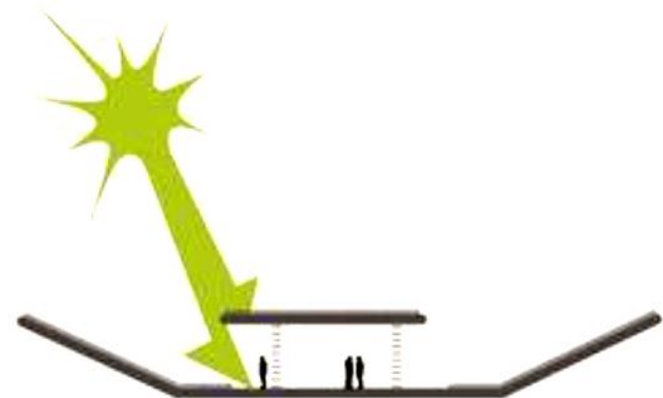

SHADOW TERRACES IN ROOF OASIS



DIFFUSE DAYLIGHT IN EXPOSITION SPACES



LONG VIEWS OVER GREEN ROOF



LONG VIEWS FROM GALLERY HALLWAYS



DIRECT VIEW TO PARK THROUGH GAPS





1. Maximising the site potential in accordance to the brief.

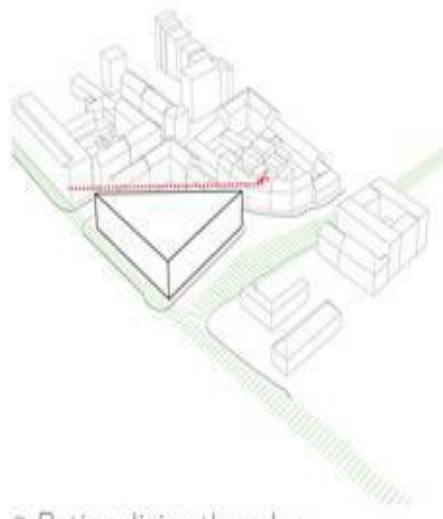

2. Rationalising the edge.

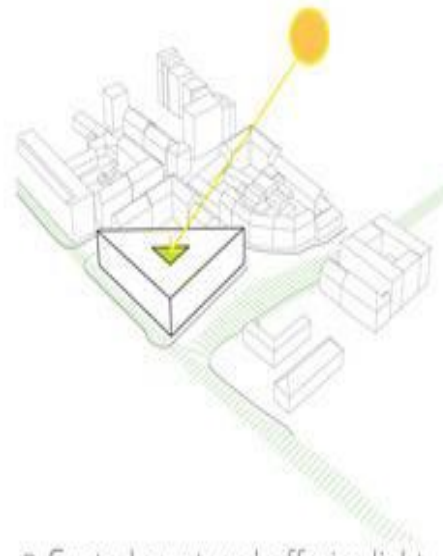

3. Central courtyard, offering light to the Roman ruins.



4. Lifting the building to preserve the Roman Ruins.

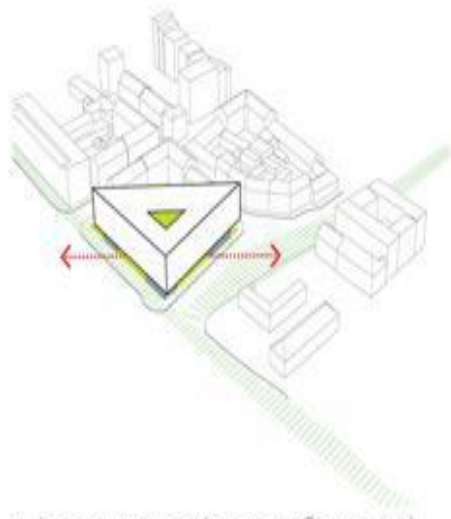

5. Improving pedestrian flows and increasing light to the public realm beneath the building.

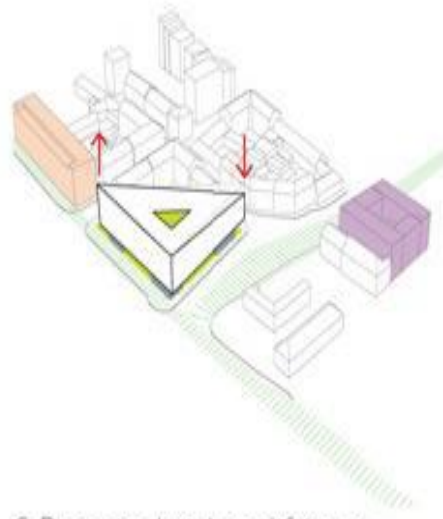

6. Dropping height or lifting to respond to NUK1 and Arts faculty building.



7. Splitting the form to maximise potential for views and the allow form to meet the ground.



8. Activating the roof scape to become part of the urban landscape.





SEED OF FAITH



SEED DIES



NEW LIFE



LIFE OVERFLOWS

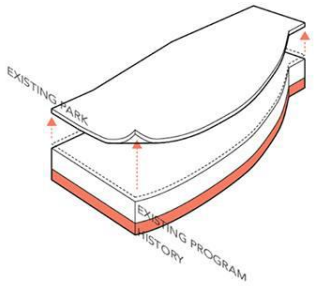

REVEALING

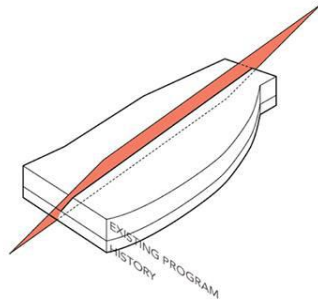

CUTTING

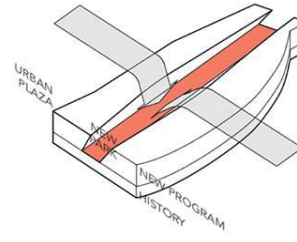

EMPTYING

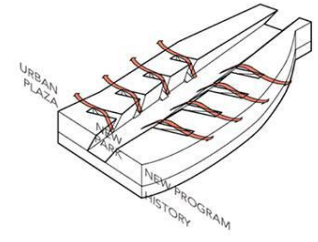

LINKING

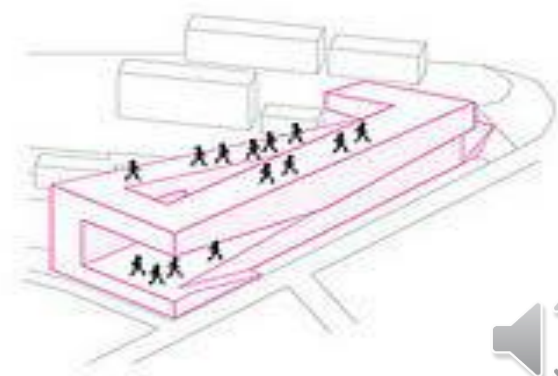
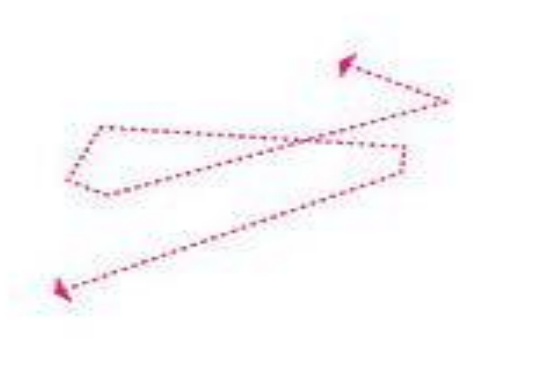
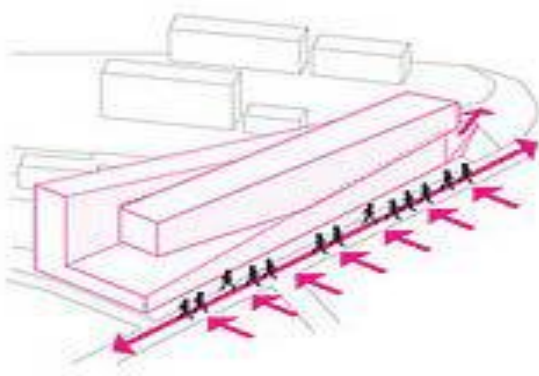
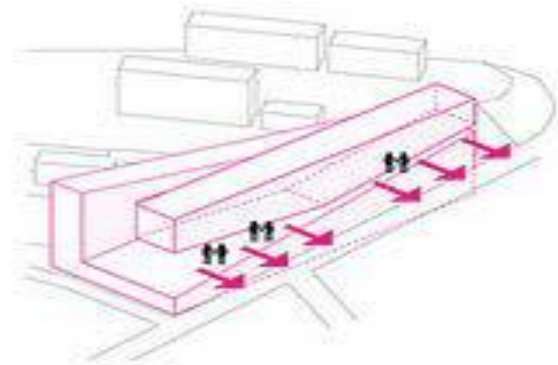
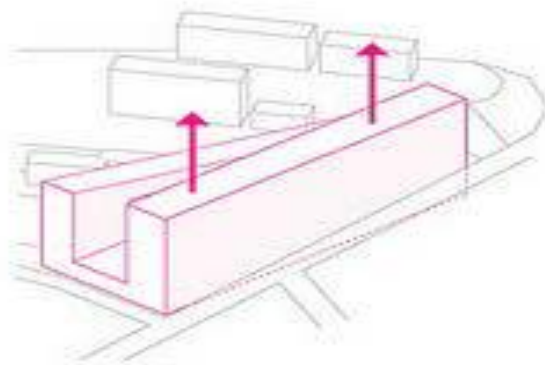
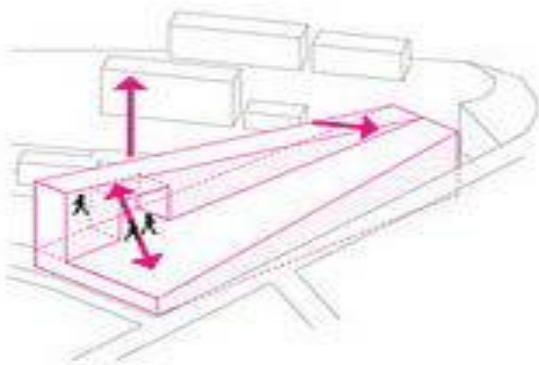
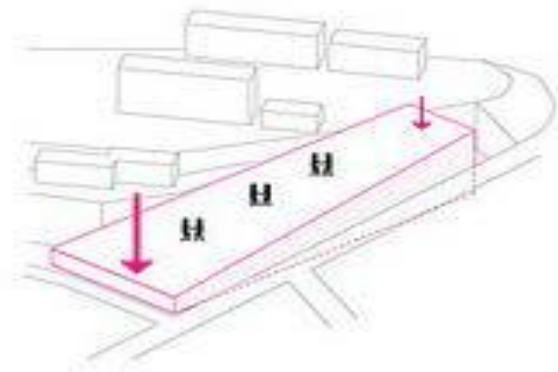
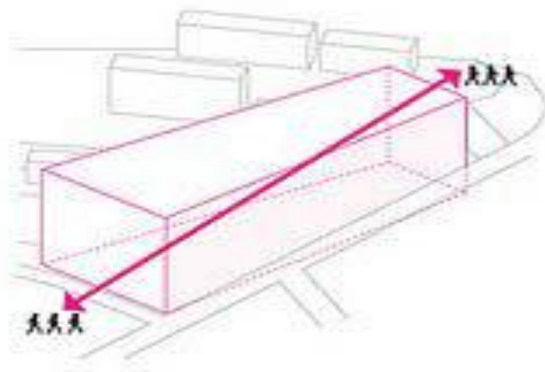
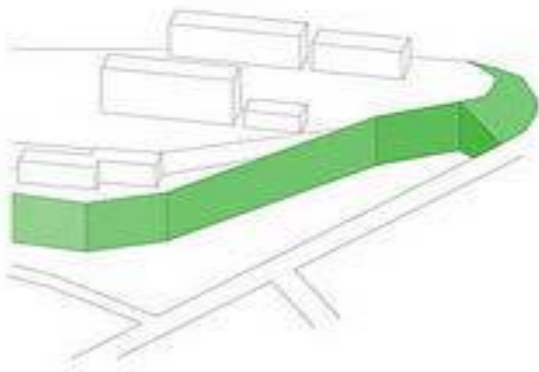

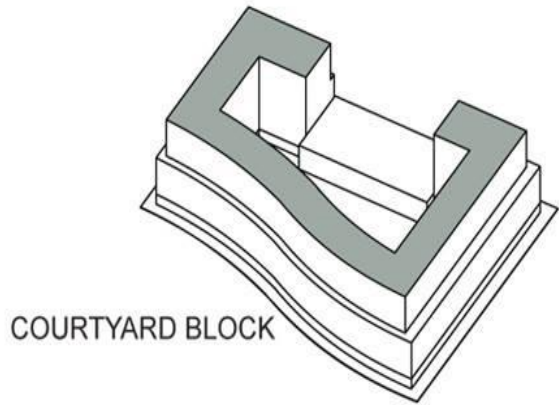

+

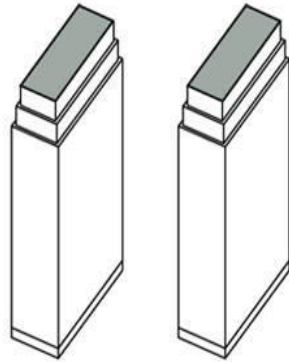

NEW YORK CITY TOWER

=

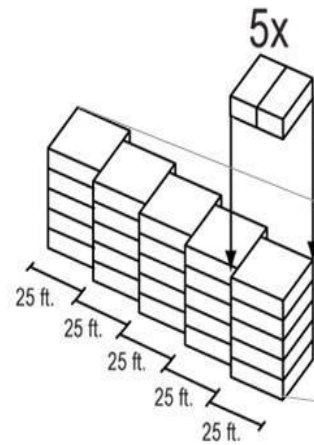
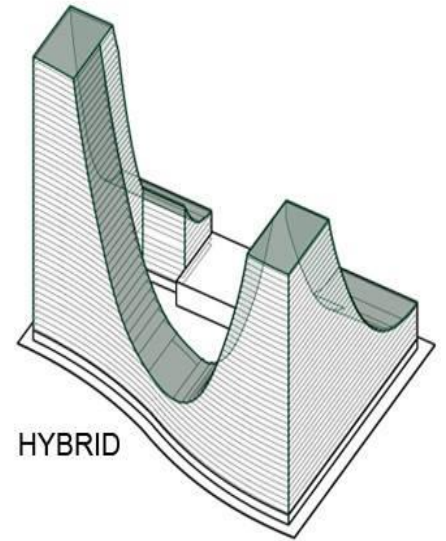

INTRODUCE THE NEW YORK  
25 FOOT TOWN HOUSE SCALE

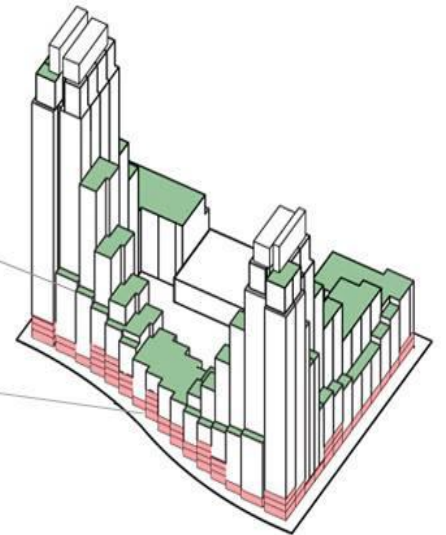

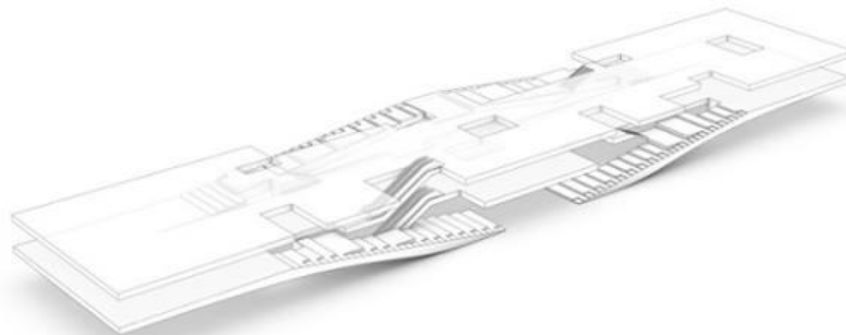
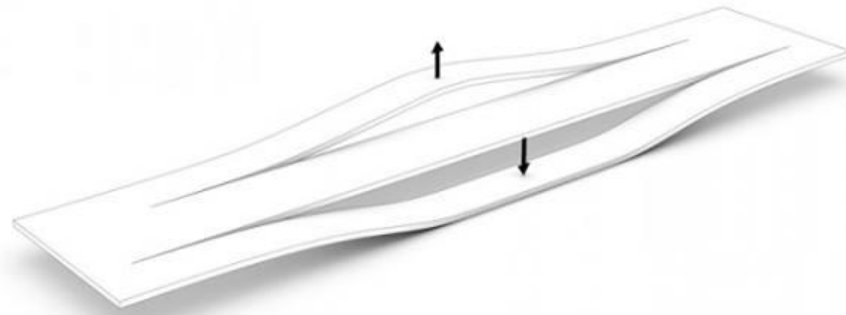

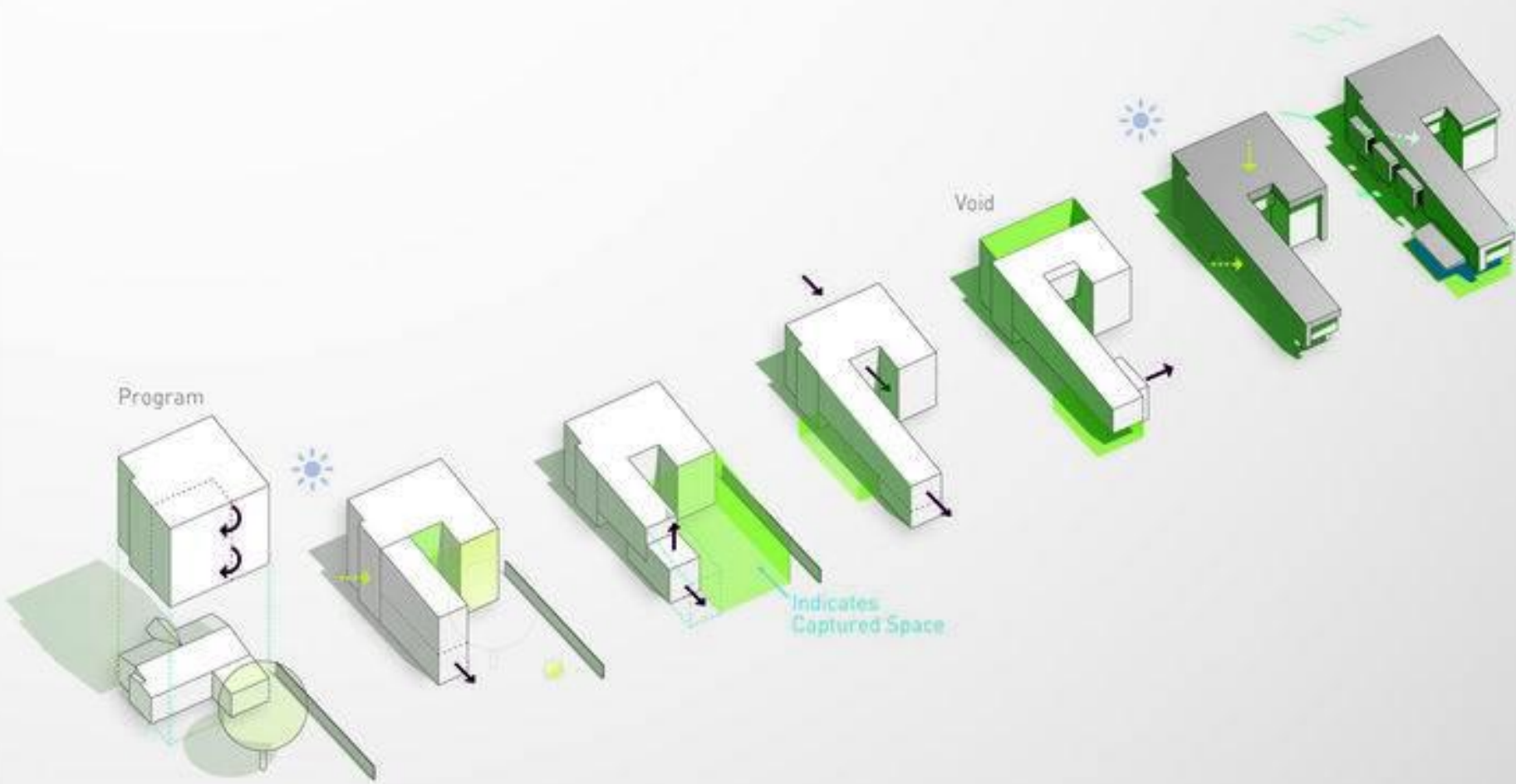

## Diagrammatic Evolution.



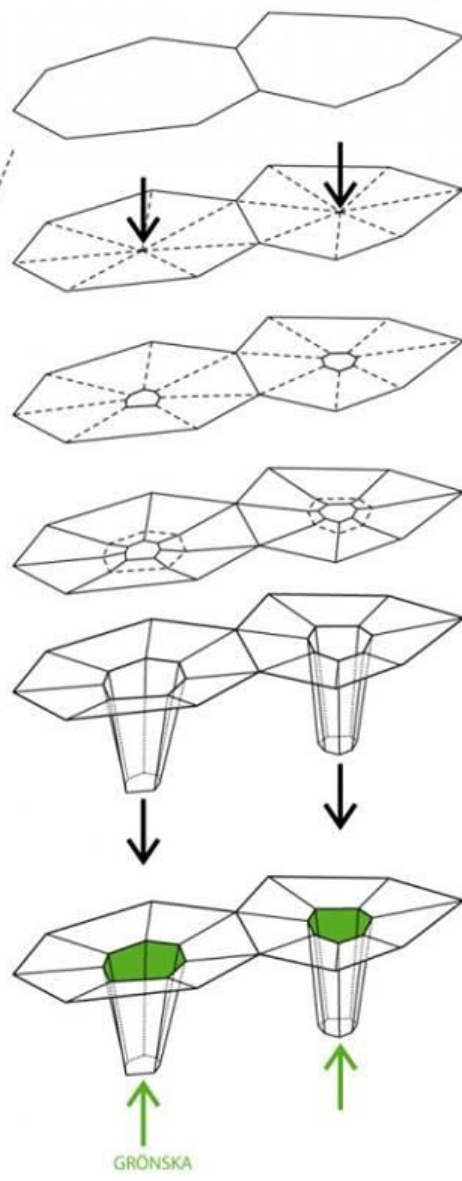
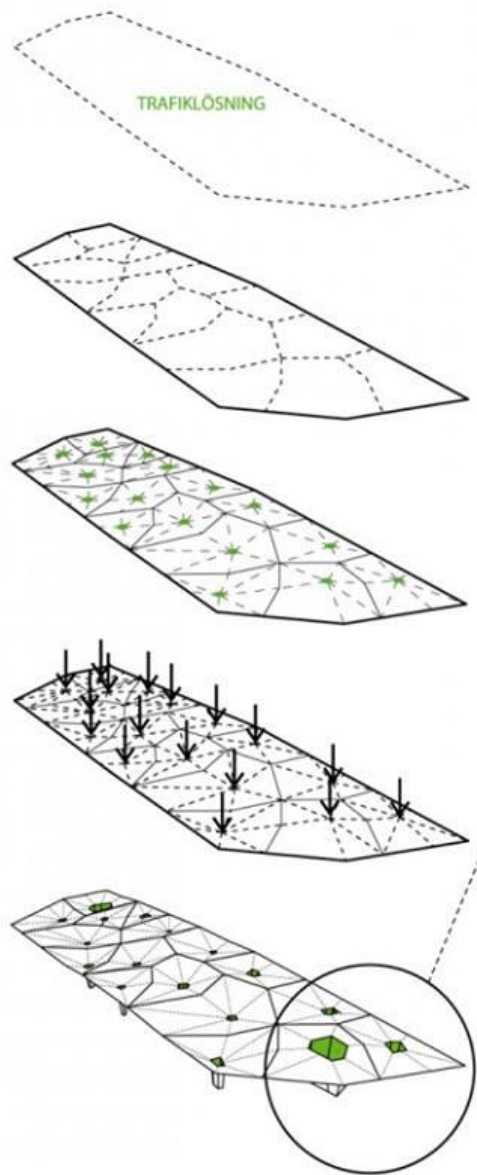

### Design Concept 3- Urban Podium

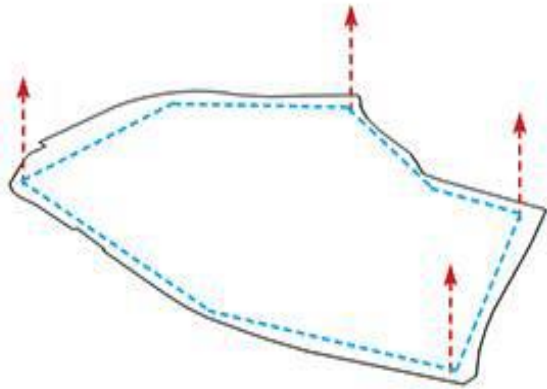

creating raised podium from site footprint

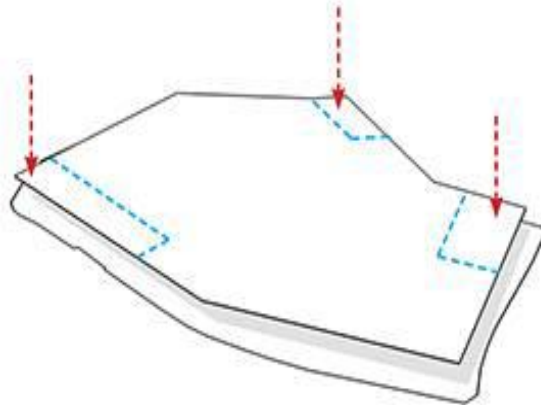

cutting the 'paper edges'

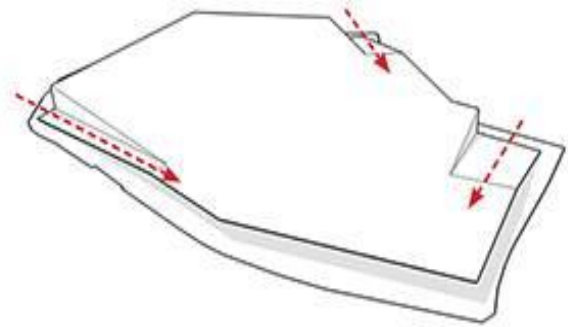

peel down podium corner for pedestrian ramps

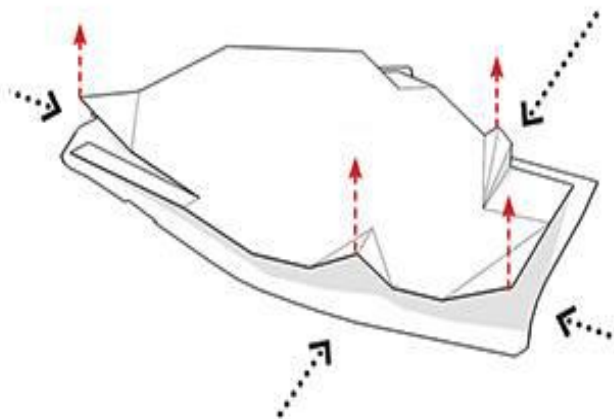

fold up to create entrances at street notes

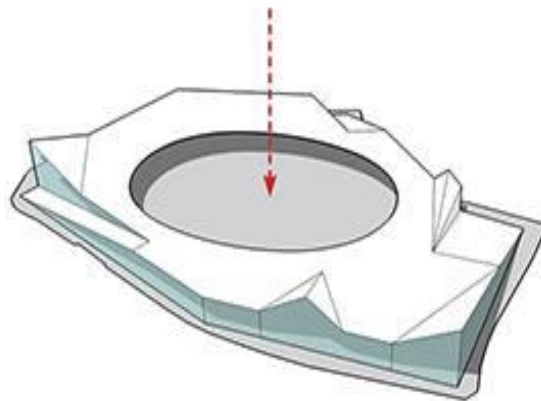

sink first tier of stadium

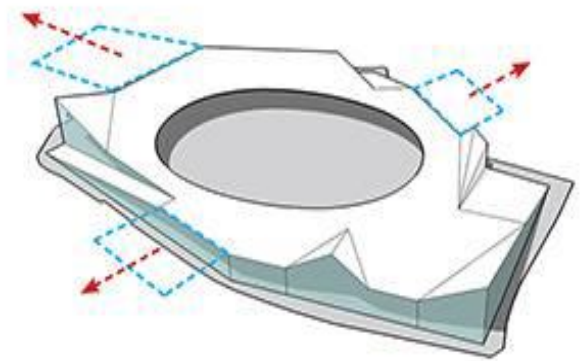

use 'sky bridges' to connect to nearby sports facilities



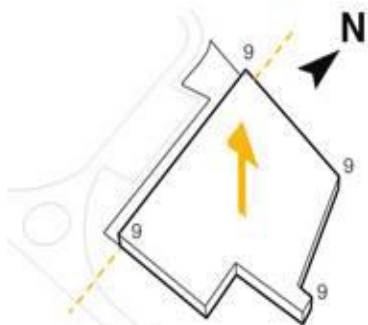

#### SATURAZIONE LOTTO

edificando tutta la superficie disponibile si ottiene un volume di 3 piani.

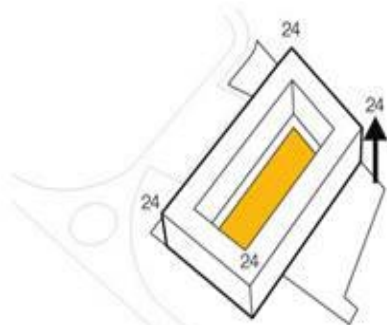

#### EDIFICIO A CORTE

la tipologia a corte, alta 8 piani, delimita uno spazio interno introverso.



#### VARIAZIONE VOLUMETRICA

la compressione del volume a corte genera 2 nuovi spazi che dialogano col contesto.

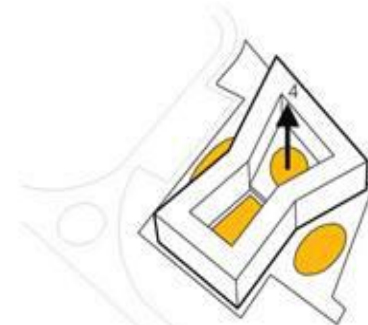

#### INNALZAMENTO CORTE INTERNA

parte della corte si alza di un livello e crea 2 spazi distinti.



#### PERMEABILITA' EDIFICIO

l'edificio viene diviso e si crea una permeabilità interno-esterno.

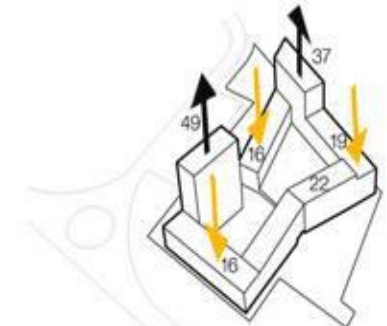

#### VARIAZIONE DI ALTEZZE

l'esposizione solare e il contesto guidano le variazioni volumetriche dell'edificio.

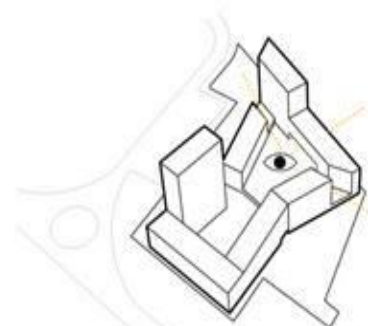

#### VISUALI DALLA CORTE RIALZATA

i tagli nell'edificio consentono di avere differenti scorci dalla corte condominiale.

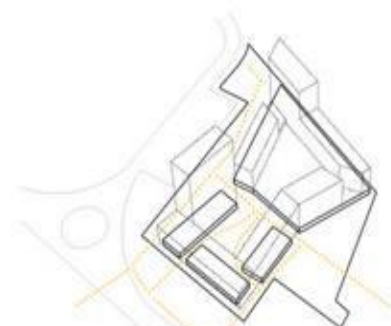

#### PERMEABILITA' PIANO TERRA

i passaggi pedonali favoriscono il rapporto col contesto circostante.





"Cycle Of Life"  
"生命的循环"

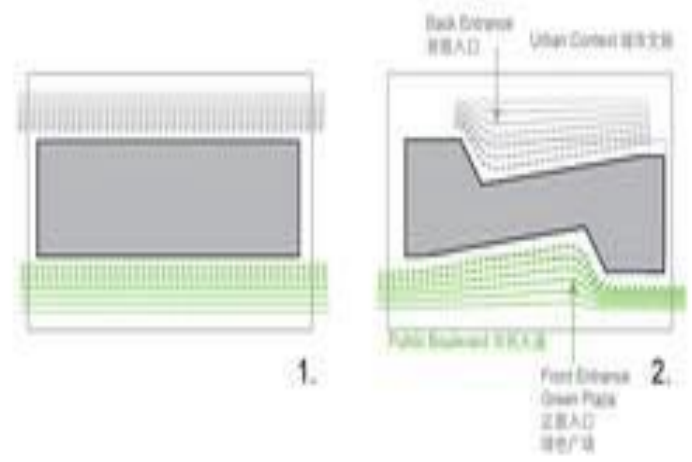
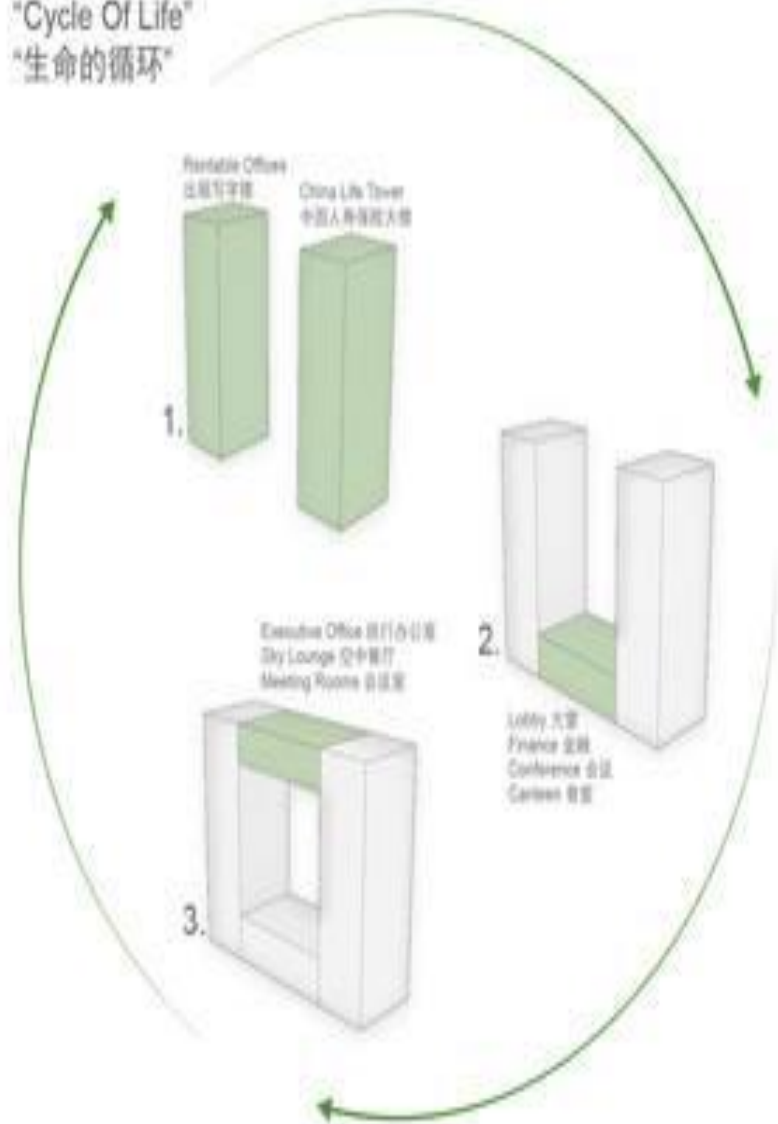

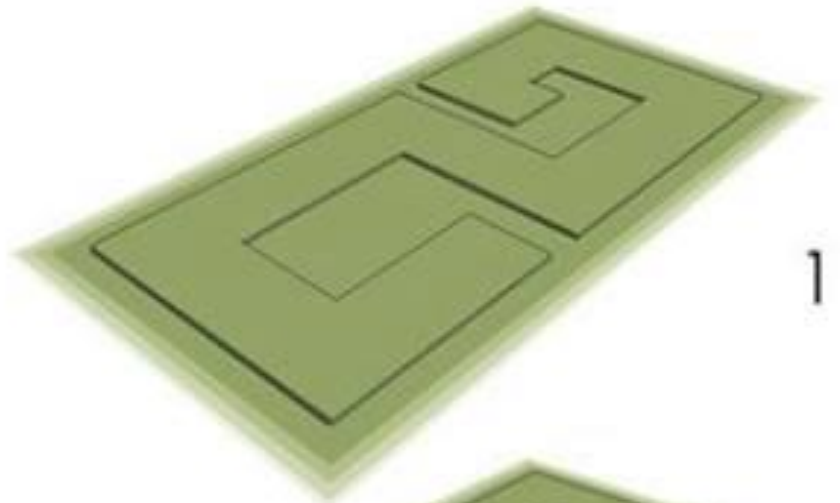
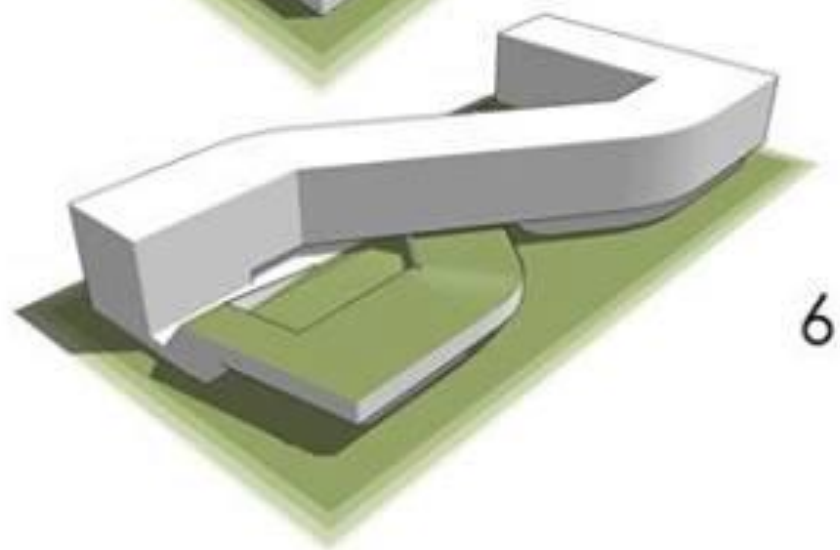
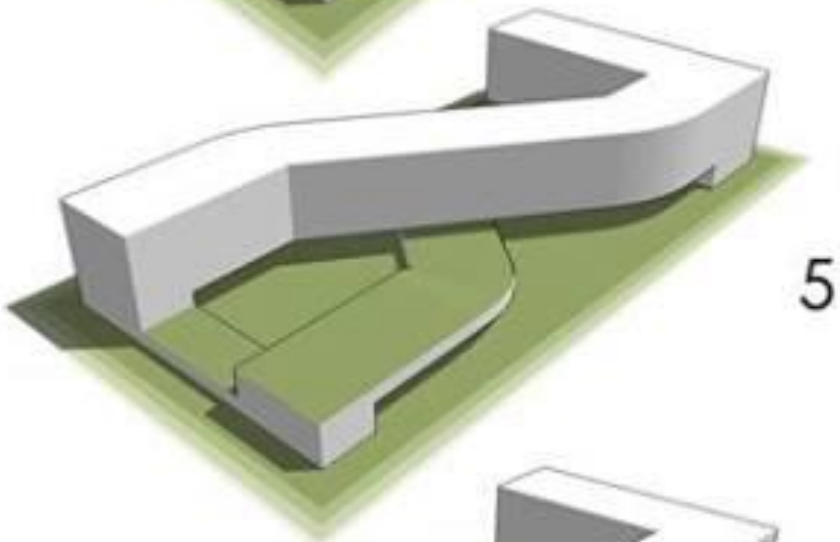
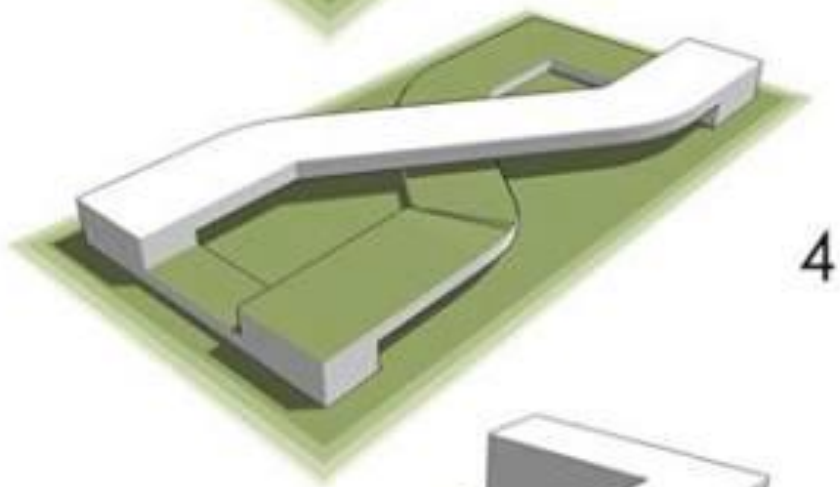

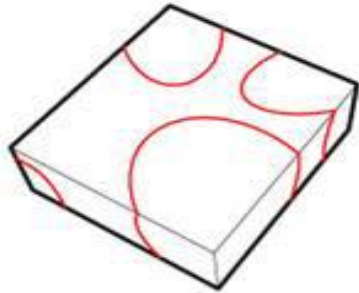

THE LINES PROJECTED ON THE EXTERIOR SKIN WILL BE UTILIZED TO FORM THE ROOF.

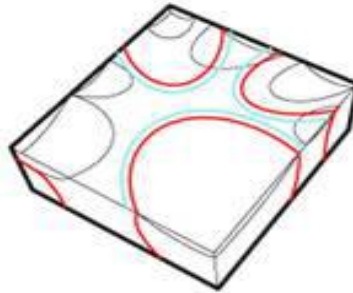

WE THEN ADD NEW CURVES TO FORM THE FINAL IMAGE OF THE ROOF, AND IN ORDER TO PERCEIVE THE SHAPES IN THE ATRIUM WE OFFSET THE CURVES IN THE ROOF, PROVIDING NATURAL LIGHTS.

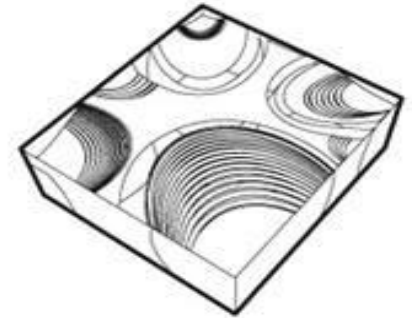

WE CUT THE ROOF AGAIN IN THE PROXIMITY OF THE ROOF OF EACH EGGS IN ORDER TO PROVIDE NATURAL LIGHTS ON THE 7TH FLOOR.

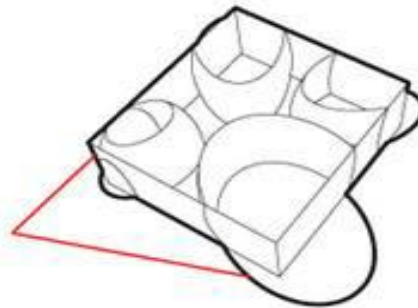
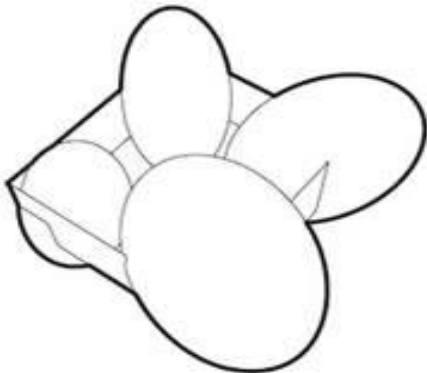

WE CUT THE EGGS AND IN THE INSIDE THE BOX THEY BECOME OUR EXHIBITION SPACES OUTSIDE THE ELLIPSE GIVE SHAPE TO THE LANDSCAPE.

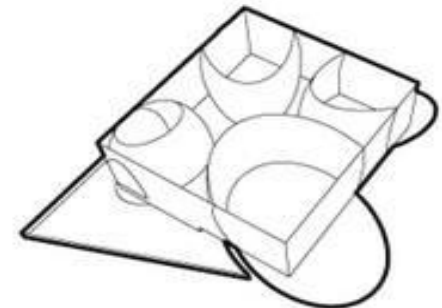

WE PUSH DOWN THE SOUTH WEST CORNER TO FORM A SUNKEN GARDEN.



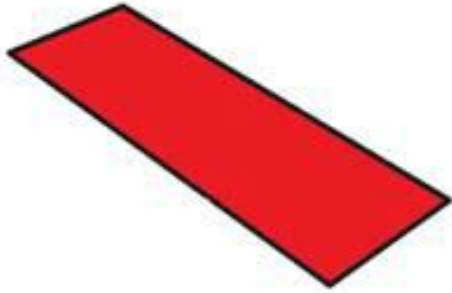

STEP 1: AREA

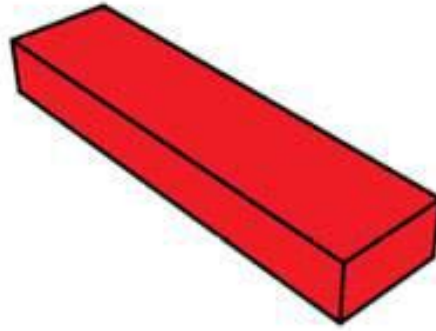

STEP 2: TENNIS CLUB VOLUME

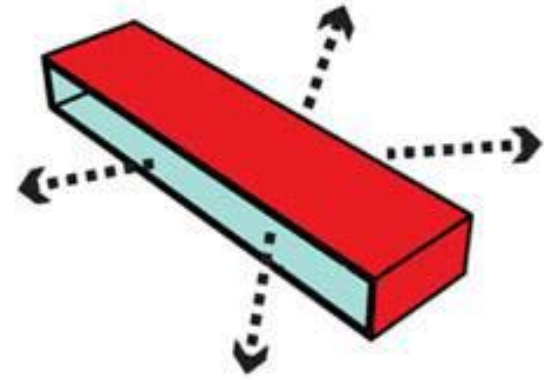

STEP 3: OPEN FOR VIEWS

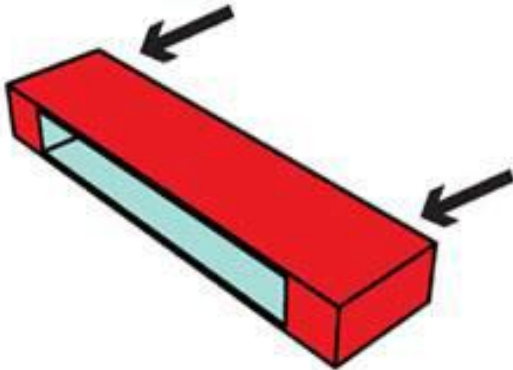

STEP 4: ADD CHANGING ROOMS

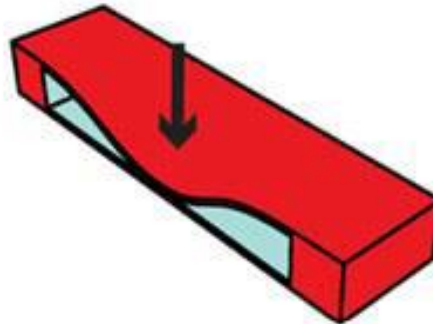

STEP 5: PUSH DOWN FOR ACCESS

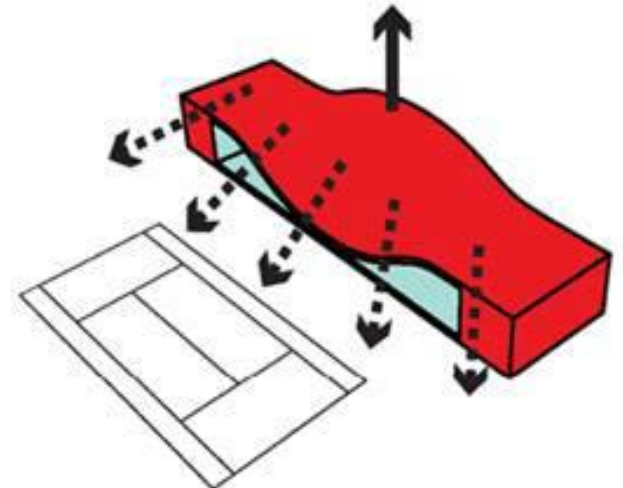

STEP 6: LIFT FOR BETTER VIEWS



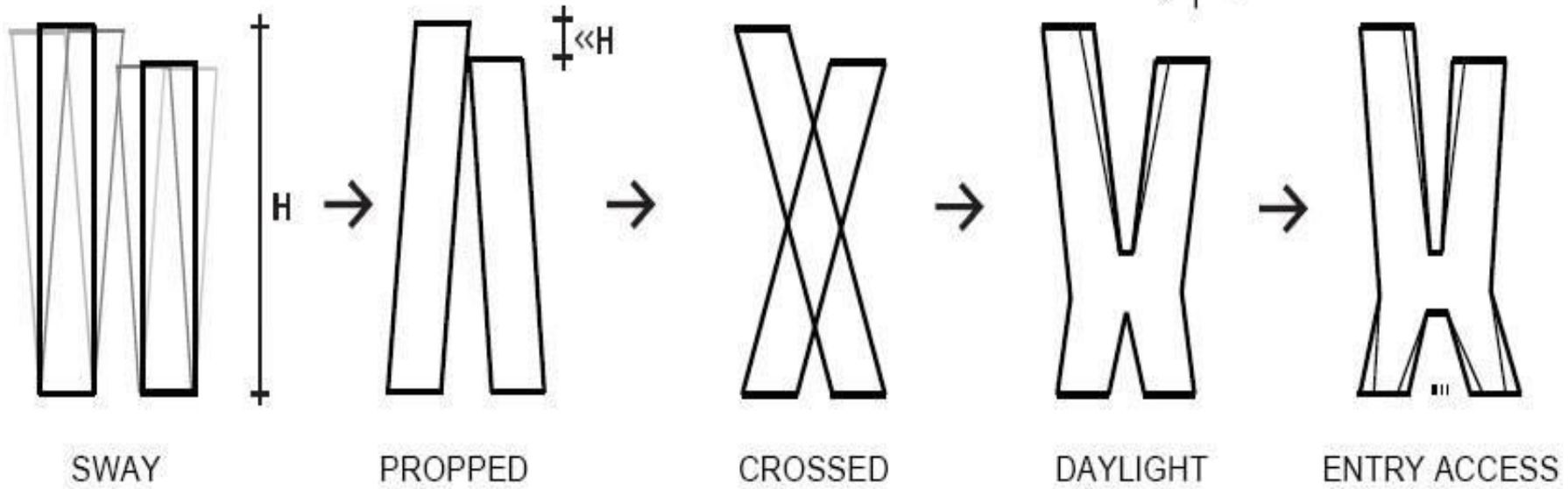

DESARROLLO DEL VOLUMEN

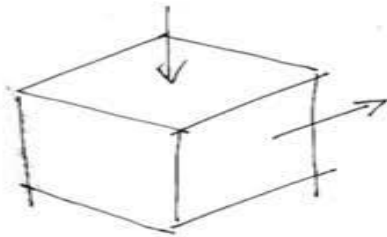

1 Volumen Formal Base

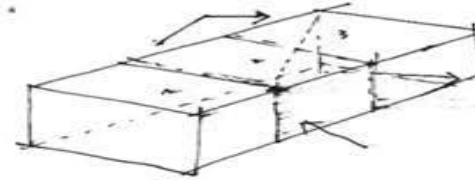

2 Extensión y Aplanado

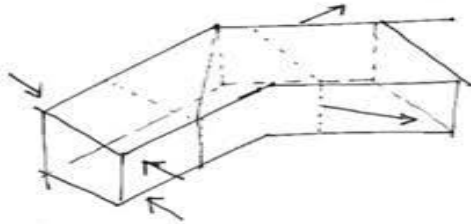

3 Quiebre

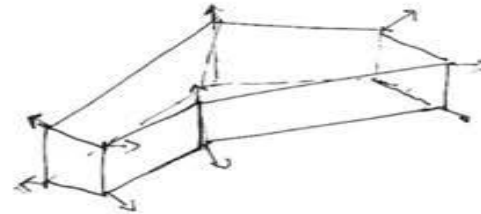

4 Extencion y Fugas

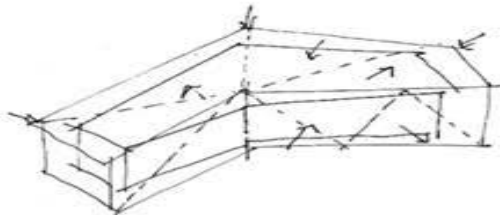

5 Doble Piel

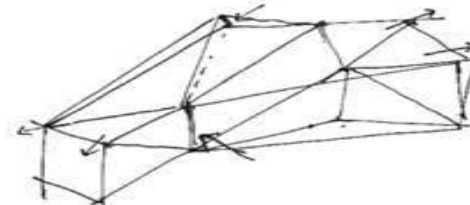

6 Triangulación, Transgresiones  
incorporación de aleros

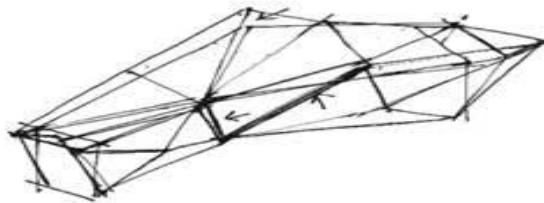

7 Tomas de Aire y Pendientes  
Sombras de Viento

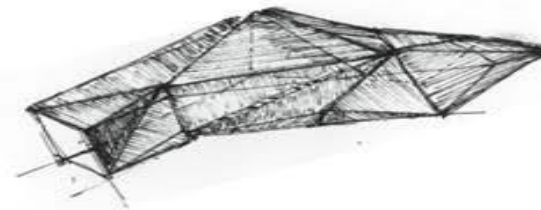

8 Forma y Volumen



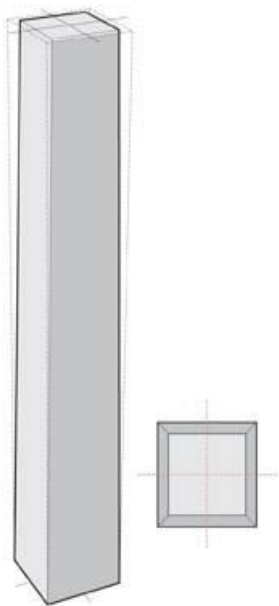

体块  
Mass

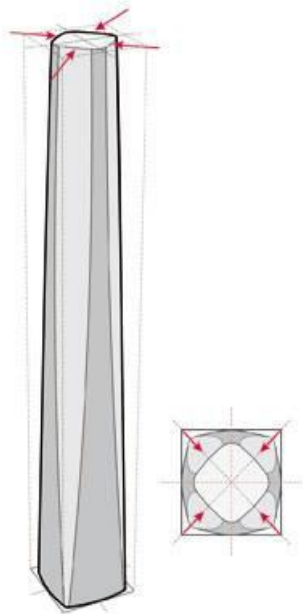

锥型渐变  
Tapered Corners



巨型支撑结构  
Mega-Columns

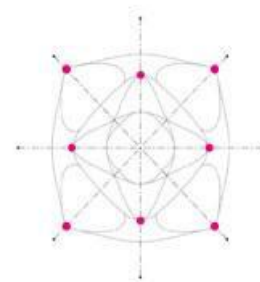

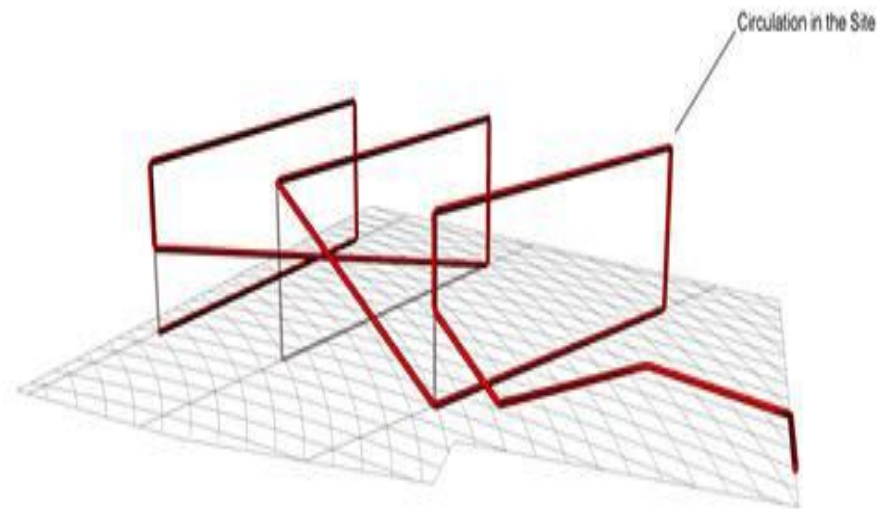
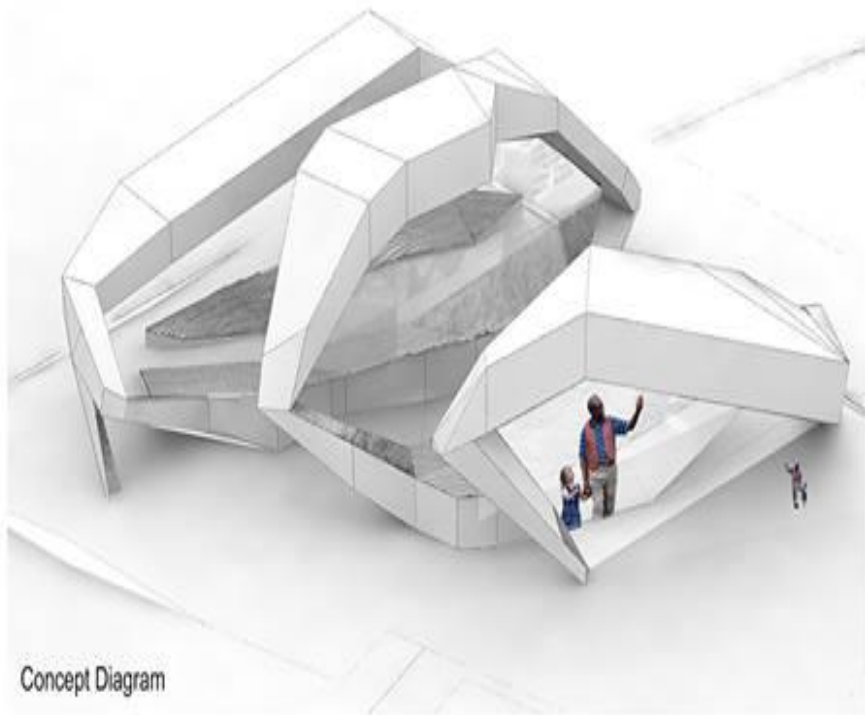
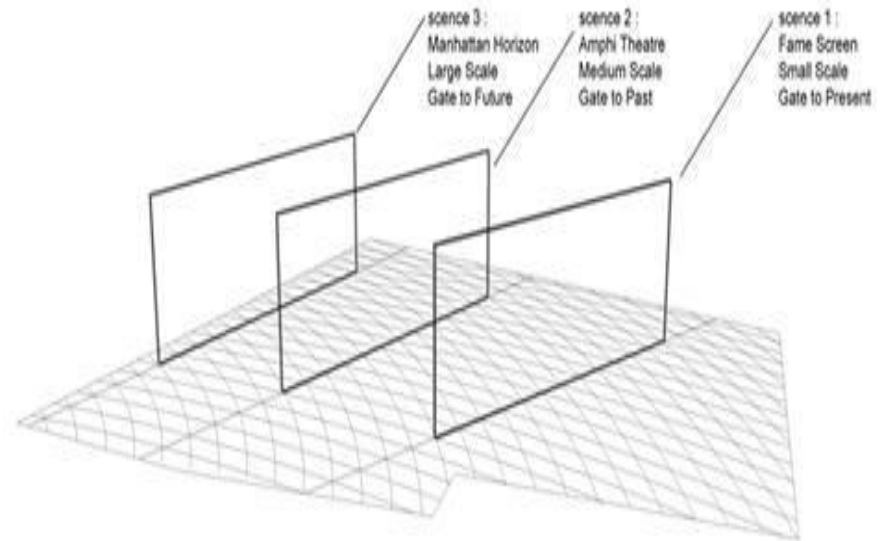
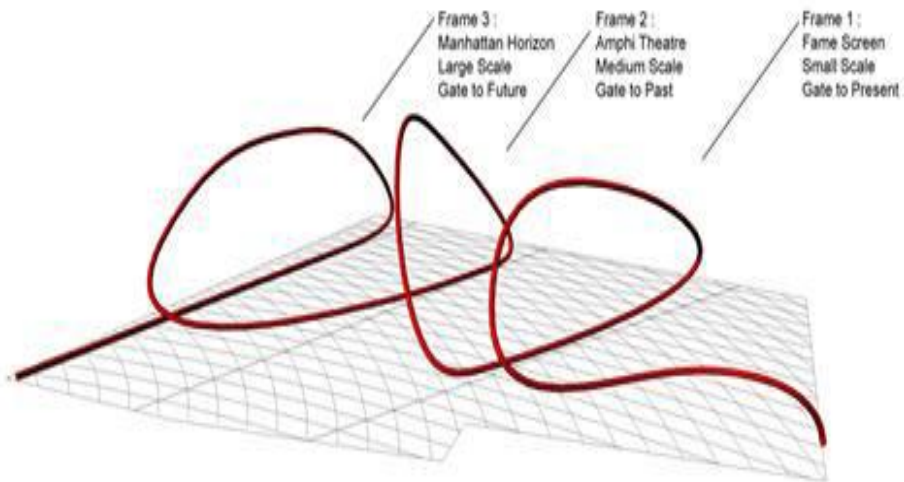



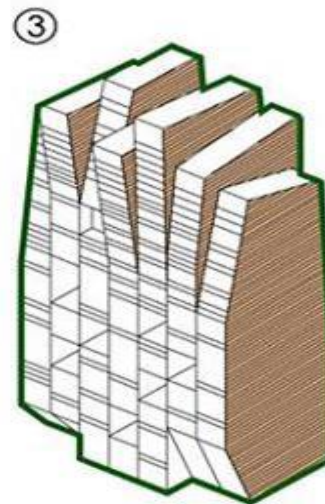
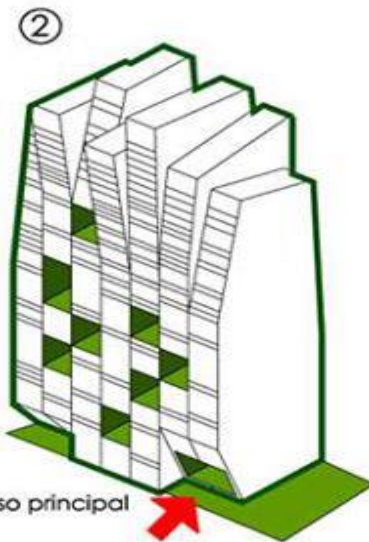
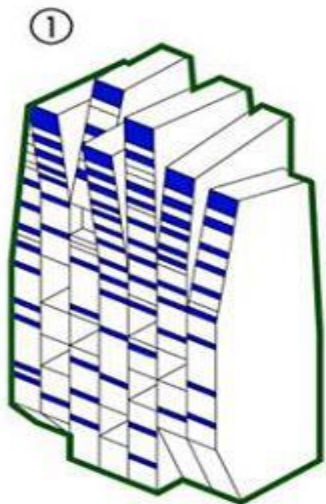
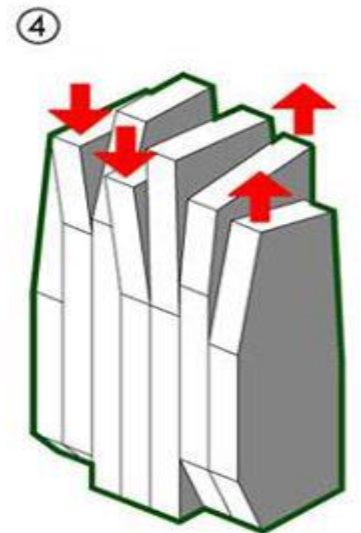
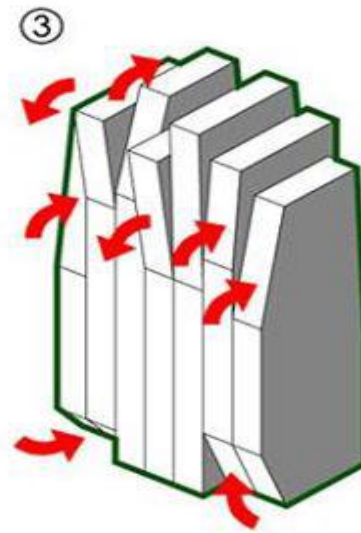
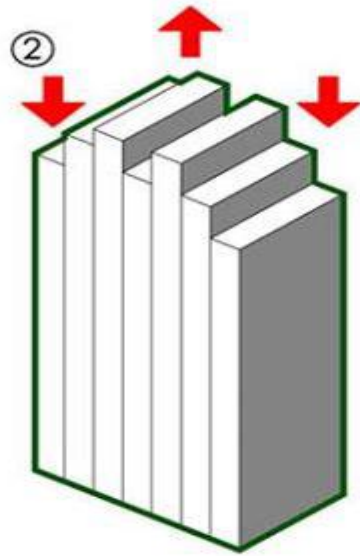
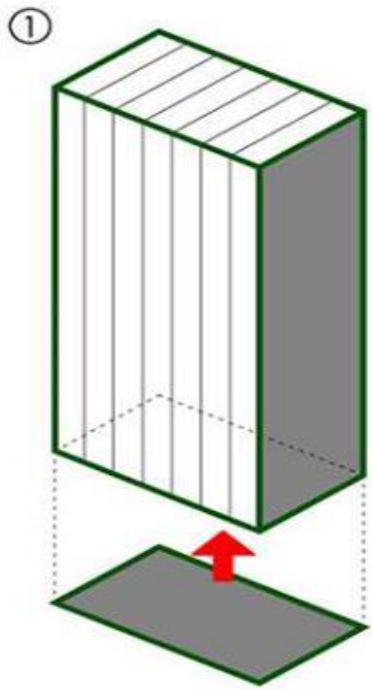

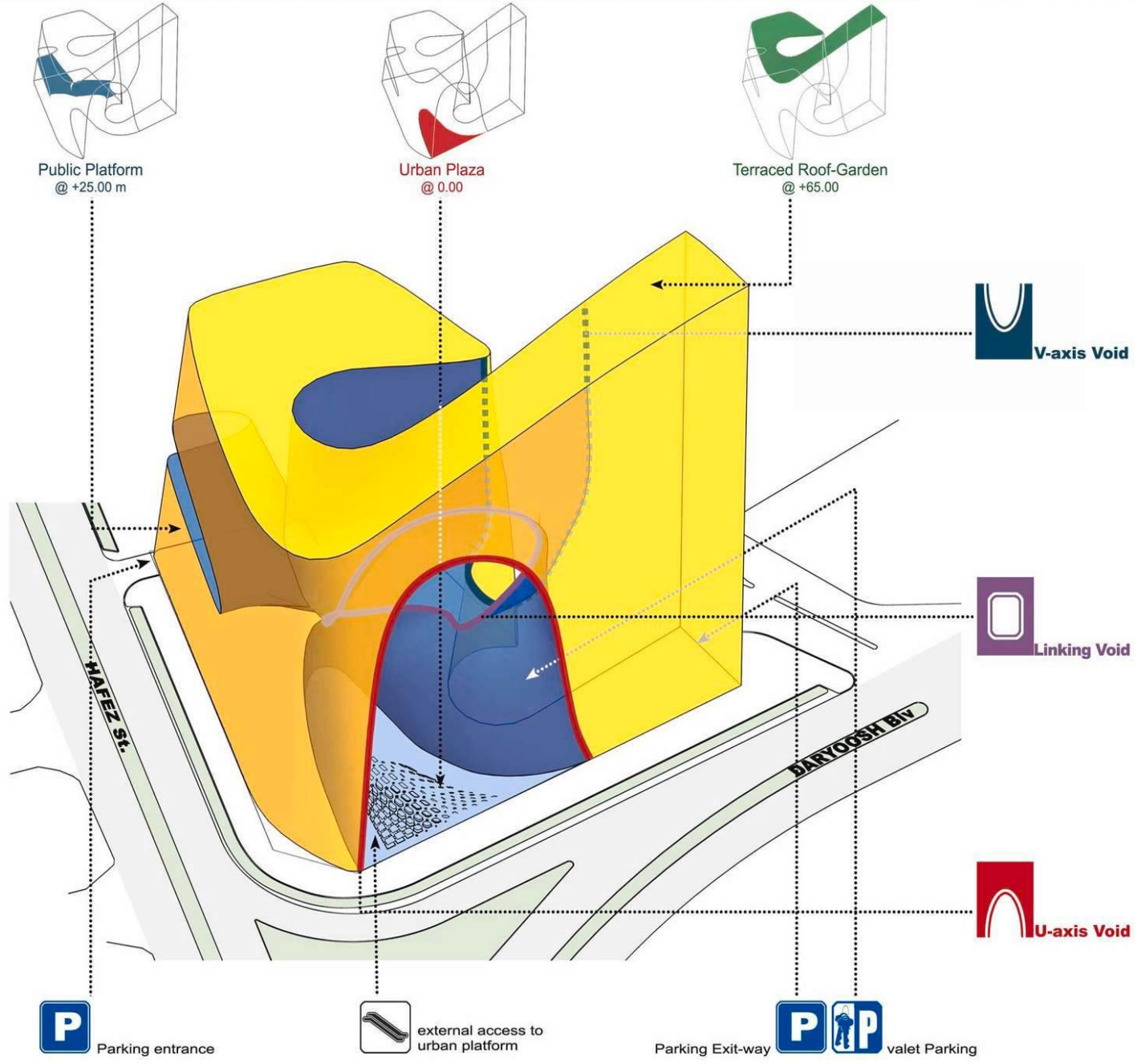

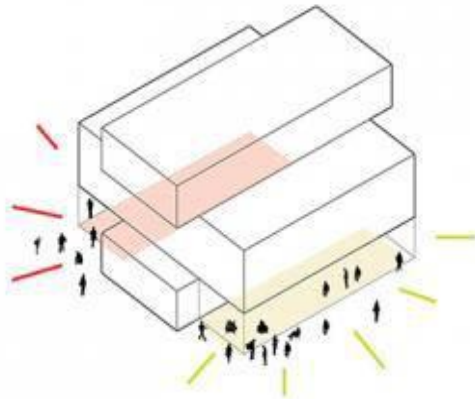

**STRONG CONNECTION WITH PUBLIC SPACE**



**CLEAR PROGRAMMATIC IDENTITY**

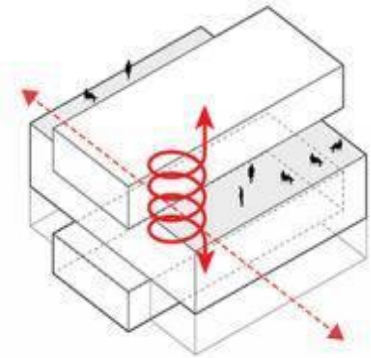

**VERTICAL CONNECTION ACTIVE COMMUNICATION**

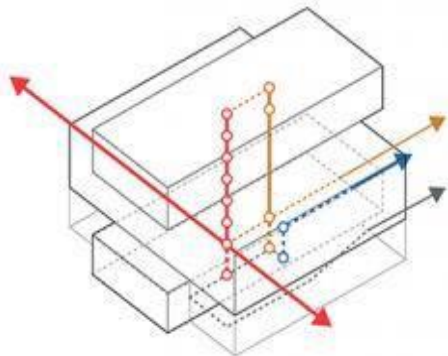

**SEPARATE ORGANISATION PROGRAM**

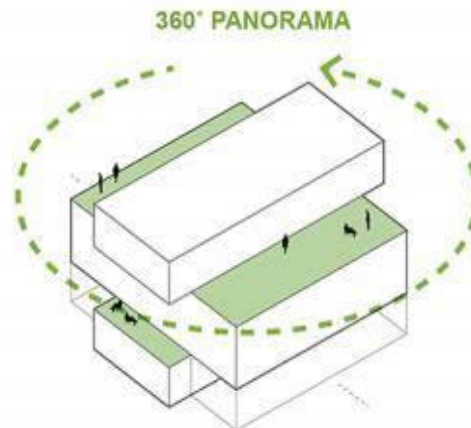

**GENEROUS TERRACES**

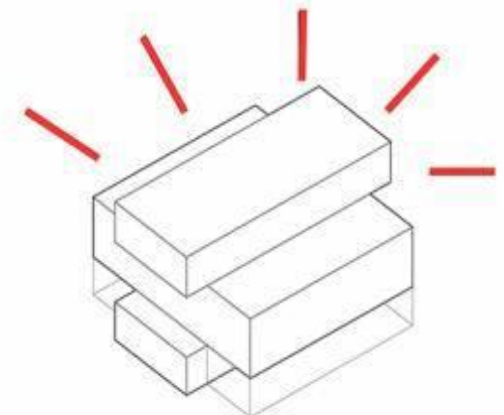

**STRONG IDENTITY FOR KUNST-CAMPUS**



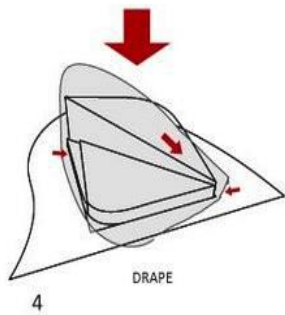

DRAPE

4

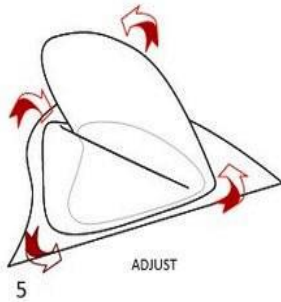

ADJUST

5

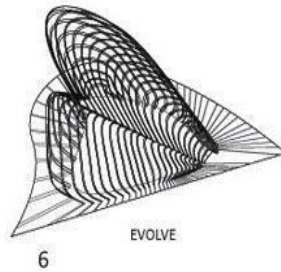

EVOLVE

6

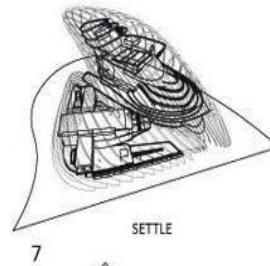

SETTLE

7

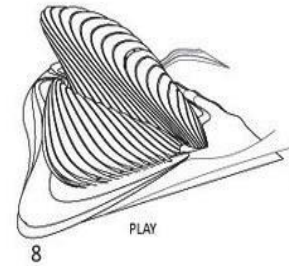

PLAY

8

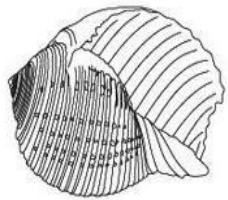

## \_FORM

MUSIC SHELL  
SYMBOLIC REFERENCE TO SEA SOUNDS AND ECOS

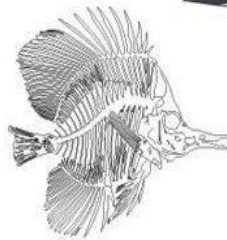

## \_SKIN

BUTTERFLY FISH SKELETON & TRANSPARENCY  
INDIAN AND PACIFIC OCEAN ICONIC FISH

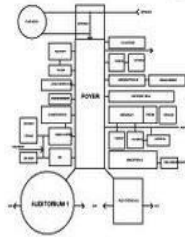

## \_PROGRAM

58,000 SQM USE & RELATION  
NEW CENTRE AND CULTURAL GATEWAY FOR BUSAN

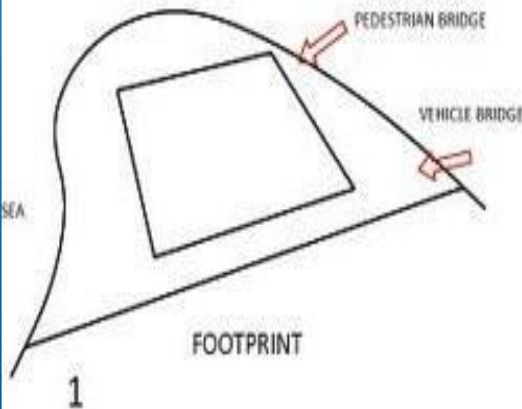

FOOTPRINT

1

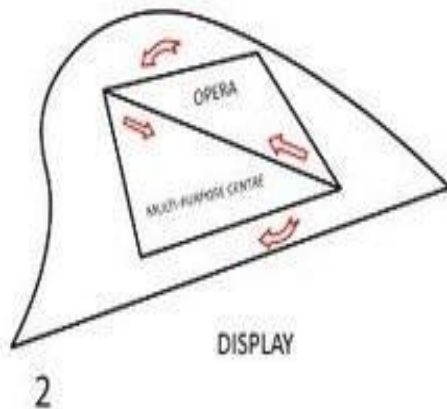

DISPLAY

2

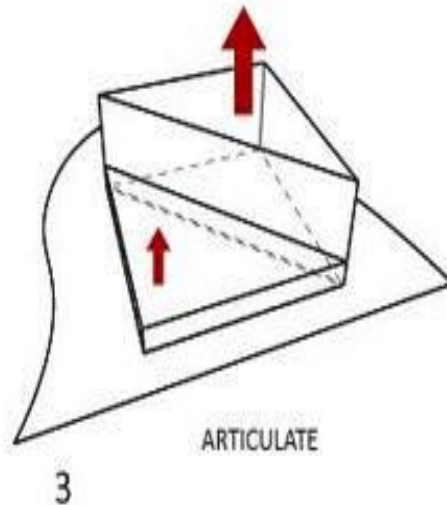

ARTICULATE

3



## \_THEME

OPERA & MULTI-PURPOSE CENTRE  
BUSAN, SOUTH KOREA

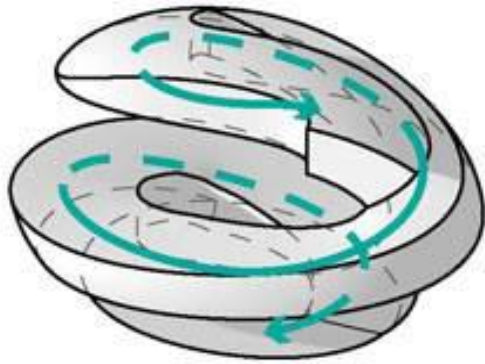

HELICOIDAL 1 UP/DOWN

+

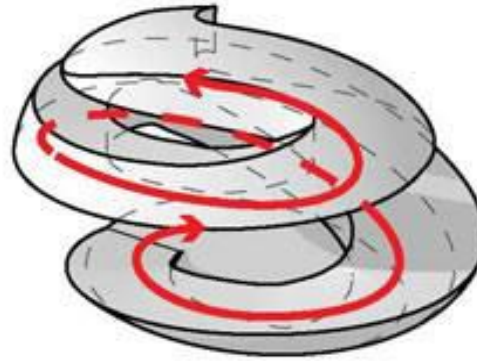

HELICOIDAL 2 DOWN/UP

=

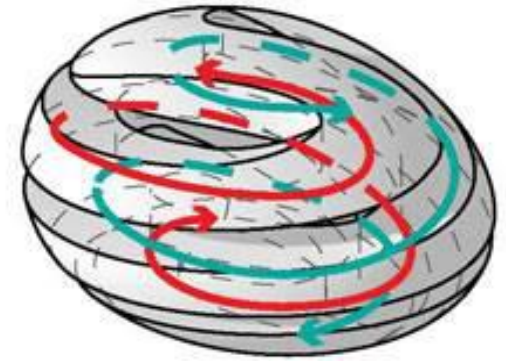

CONTINUOUS CIRCULATION

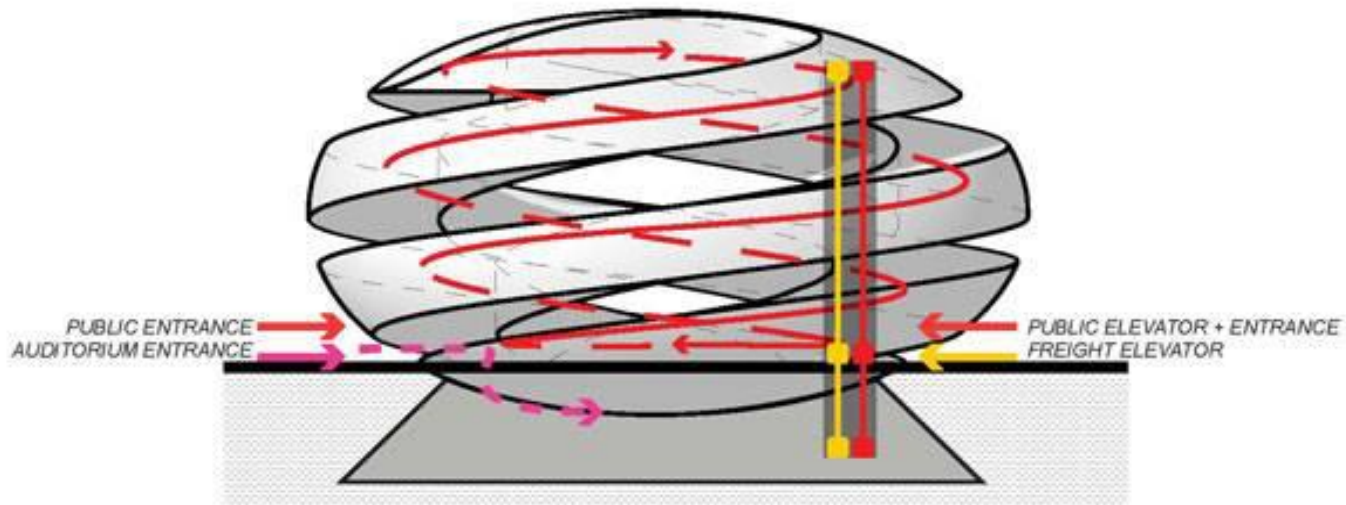

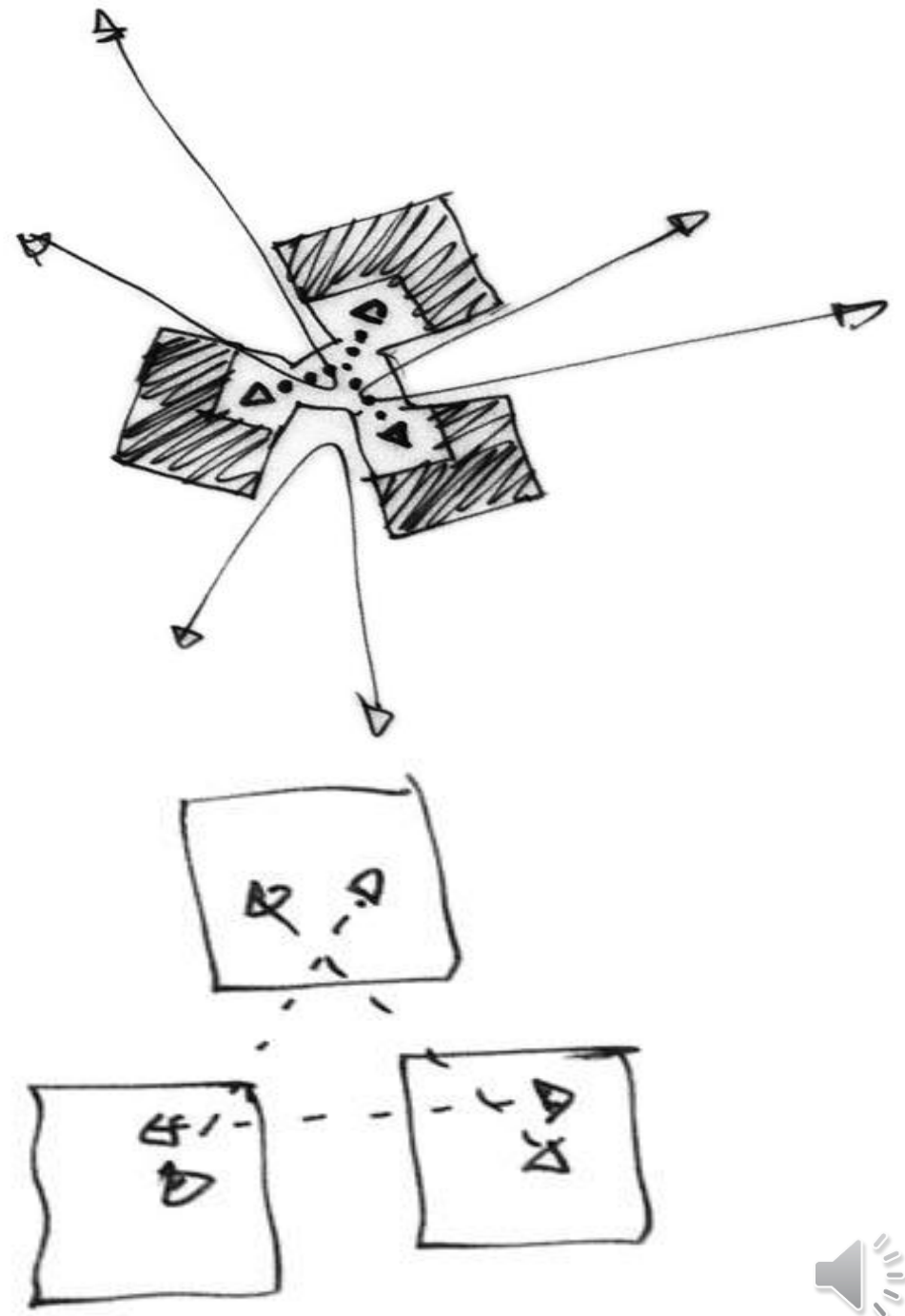
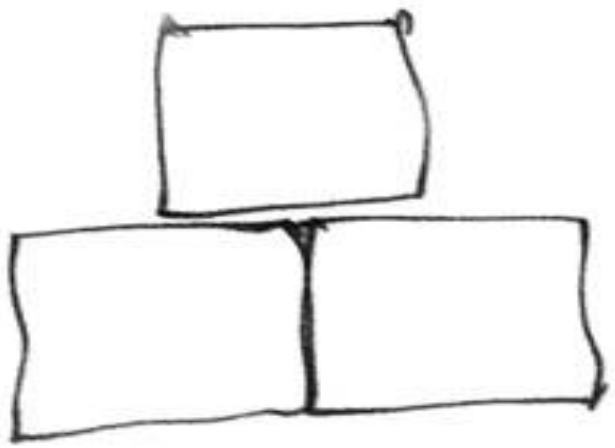
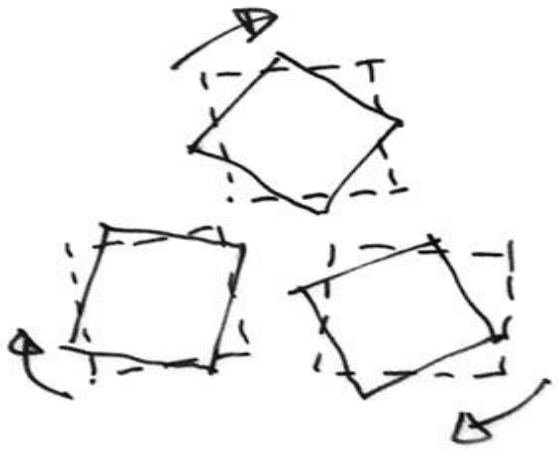

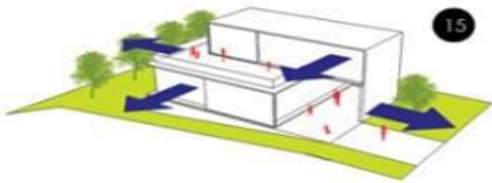
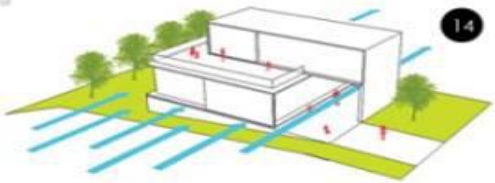
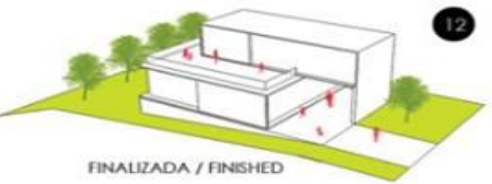
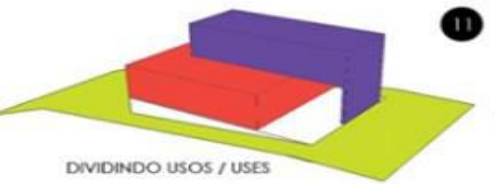
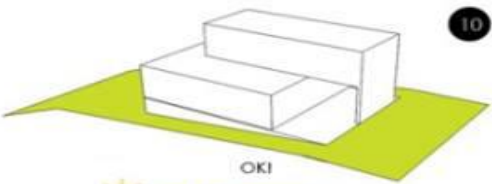
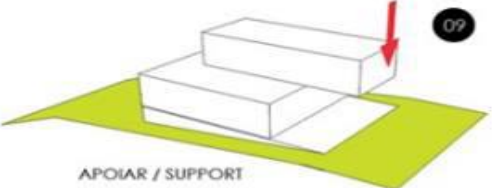
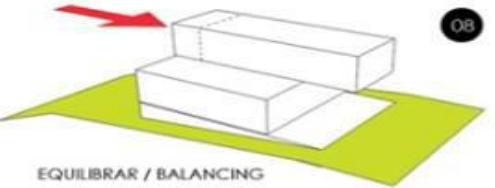
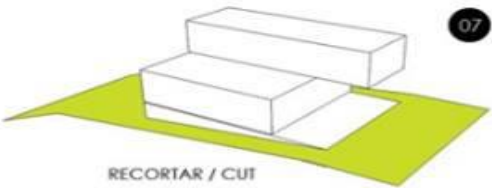
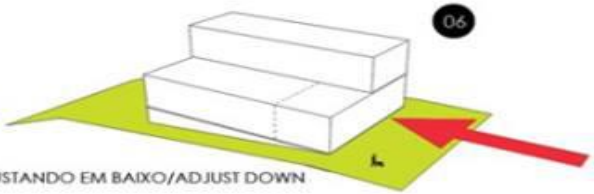
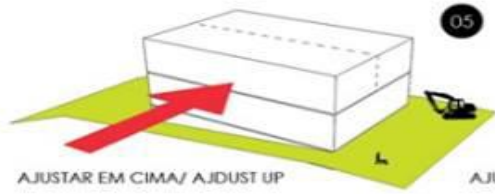
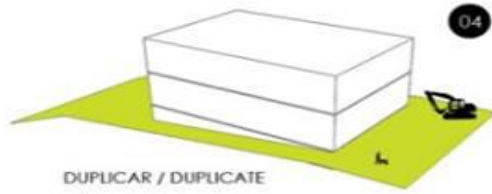
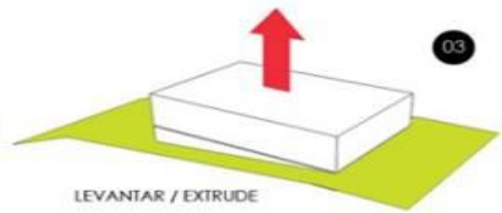
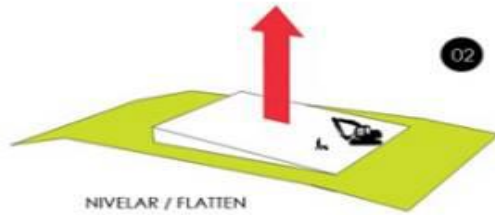

شكرا لحسن الاصغاء

